



VASEN PE PIPING SYSTEM

ZHEJIANG WEIXING NEW BUILDING MATERIALS CO., LTD.

West Jiangshi Road, Economic Development Zone of Linhai, Zhejiang Province, China

P.C.:317000

TEL:+86-576-85176016 FAX:+86-576-85176826

Email:info@vasen.com

http://www.vasen.com

www.vasen.com

Contents

1. Company Profile
2. Quality Assurance System
3. Introduction of PE Material
4. Material Characteristics of PE100
5. Characteristics of VASEN PE Piping System
6. Applications of VASEN PE Piping System
7. Design of the System
8. Connection Methods
9. Installation and Maintenance
10. General Precautions
- 1 1. Product Range

Section 1

Company Profile

Weixing group was established in 1976, after a steady development, it grew to a state-level conglomerate group. More than 25,000 current employees are recruited by Weixing group and its total property amounts over 3 billion USD with the sales volume over 2 billion USD. Weixing group owns 6 industries and 13 industry parks and 2 listed companies. Zhejiang Weixing New Building Materials Co., Ltd. is one listed.

Zhejiang Weixing New Building Materials Co., Ltd. (hereinafter referred to as Weixing NBM), was established in 1999 and listed in 2010. We have complete product line, massive scale of production, smart management branding. Meanwhile, we have taken the positions of vice-president of China Plastic Process Industry Association and vice-chairman of China Plastic Piping Association for successive years.

Weixing NBM has production bases in Zhejiang, Shanghai, Tianjin, Chongqing and Xi'an. The core products are PP-R piping system, PE piping system, PB and PE-RT piping system and PE double wall corrugated piping system, etc., which are widely applied in the fields of water supply, drainage, gas, heating, the electric power transmission, mine and so on.

Through great efforts, Weixing NBM takes the lead in passing ISO9001 Quality Management System and ISO14001 Environmental Management System, DVGW, TUV, CE, AENOR, WRAS, ACS, NSF and other international certificates. The test center also obtained the certificate of CNAS (China National Accreditation Service for Conformity Assessment).

The sales network of Weixing NBM covers the China domestic market and 5 continents, 12 regions and 40 countries.



Section 2

Quality Assurance System

Adhere to high-quality business philosophy and quality oriented, we introduced a modern quality management system to create three Quality Assurance Systems and implement quality leadership strategy to ensure the safety and excellence of product quality.

Quality Assurance System Framework:



Quality Assurance Systems

Top-level Quality Assurance System

Around the 5M1E (man, machine, material, method, measurement, environment) we reinforced the top-level security assurance planning. We formulated the most rigorous inner quality standard and laid emphasis on the input of superior raw material and auxiliary material and out of high quality products based on the latest international and national standards and in combination with our research achievements of production and application technology over the years. And through the intelligence, statistical methods, we forged our enterprise culture of comprehensive, whole-stuff, full processes, fine-grained quality management and never stop striving for excellence.

Monitoring System

We established a high quality platform to monitor the quality of each piece of raw material, pipe and fitting in real time, built an intelligent alarm system to help staffs deal with potential quality problems speedily, a big data platform to ensure the traceability of 5M1E information (man, machine, material, method, measurement, environment), and the smart monitoring system guarantees the safety and excellence of products.

Processing Assurance System

We introduced the latest Germany made automatic pipe extrusion lines along with advanced fitting processing equipment from Italy, UK which assembled Centralized Raw Material Feed System, Pipe Weight Measuring System, Ultrasonic Thickness Measuring Systems, Laser Diameter Measuring System, which ensure the pipe weight, diameter, wall thickness are precisely monitored. Around the processes which may affect the quality of fittings, we built three quality defenses to prevent defective products flowing into the market.

Quality Assurance Platform

Quality Assurance Center consists of Quality Assurance Department (QA), Quality Control Department (QC) and Test Center. The test center, which accredited by CNAS, covers an area of 1,000 square meters, and consists of material analysis room, mechanical testing room, application research laboratory and hydraulic study laboratory and so on. We take "systematic, rigorous, standardized and efficient" as working motto and never stop introducing the world's leading testing equipment and building the quality assurance platform lead in the rival companies to ensure the safety and excellence of our products with goal of "precise, automatic and rapid inspection"

Standard

- ISO 4427-1-2019 Plastics piping systems for water supply and for drainage and sewerage under pressure-Polyethylene (PE) -Part 1:General.
- ISO 4427-2-2019 Plastics piping systems for water supply and for drainage and sewerage under pressure-Polyethylene (PE) -Part 2:Pipes
- ISO 4427-3-2019 Plastics piping systems for water supply and for drainage and sewerage under pressure-Polyethylene (PE) -Part 3:Fittings
- ISO 4427-5-2019 Plastics piping systems for water supply and for drainage and sewerage under pressure-Polyethylene (PE) -Part 5:Fitness for purpose of the system
- BS EN 12201-2011 Plastics piping systems for water supply, and for drainage and sewerage under pressure — Polyethylene (PE) Part 1: General
- BS EN 12201-2011 Plastics piping systems for water supply, and for drainage and sewerage under pressure — Polyethylene (PE) Part 2:Pipes
- BS EN 12201-2011 Plastics piping systems for water supply, and for drainage and sewerage under pressure — Polyethylene (PE) Part3 :Fittings
- BS EN 12201-2011 Plastics piping systems for water supply, and for drainage and sewerage under pressure — Polyethylene (PE) Part 5:Fitness for purpose of the system
- GB/T 13663.1-2017 Polyethylene piping systems for water supply-Part1:General
- GB/T 13663.2-2018 Polyethylene piping systems for water supply-Part2:Pipes
- GB/T 13663.3-2018 Polyethylene piping systems for water supply-Part3:Fittings
- GB/T 13663.5-2018 Polyethylene piping systems for water supply-Part5:Fitness for purpose of the system

Certificates

The evaluation from users and third-party is the most powerful evidence of our product quality. VASEN piping products were applied in buildings of the 2008 Beijing National Olympic Games, the Shanghai World Expo, the World Cup in Brazil and in others from internationally renowned architects. Meanwhile, our products were accredited by DVGW, TUV, CE, WRAS, DNV, ABS, LR and got authoritative certificates for our piping products correspondingly. Besides, our company also was awarded the Zhejiang Provincial Government Quality Award, Taizhou City Mayor Quality Award and many other quality awards.



Section 3

Introduction of PE Material

General

The plastics industry is more than 100 years old, but polyethylene was not invented until the 1930' s. Since its discovery in 1933, Polyethylene (PE) has grown to be one of the world' s most widely used and recognized thermoplastic materials. Today' s modern PE resins are highly engineered for much more rigorous applications such as pressure-rated gas and water pipe, landfill membranes, automotive fuel tanks and other demanding applications.

Polymers which consist only of carbon and hydrogen are called polyolefins. Polyethylene (PE) belongs to this group. It is a semicrystalline thermoplastic. Polyethylene is the most known standard polymer. The chemical formula is: $(CH_2-CH_2)_n$. It is an environmentally friendly hydrocarbon product.

Types of PE Materials

The physical properties of PE materials are specific to each grade or type, and can be modified by both variations in density, and in the molecular weight distribution. A large number of grades of PE materials are used in pipes and fittings systems and the specific properties are tailored for the particular application.

The most general types of PE materials are as follows:



Linear Low Density PE(LLDPE)

LLDPE has a chain structure with little side branching and the result ant narrower molecular weight distribution, that results in improved ESCR and tensile properties when compared to LDPE materials.

LLDPE materials may be used either as a single polymer or as a blend with LDPE in micro irrigation applications to take advantage of the material flexibility.

Low Density PE (LDPE)

The density of LDPE ranges between 0.910~0.940 g/cm³ and LDPE exhibits high flexibility and retention of properties at low temperature.The main use for LDPE in piping is in the micro irrigation or dripper tube applications with sizes up to 32 mm diameter.

LDPE materials may be modified with elastomers (rubber modified) to improve Environmental Stress Crack Resistance(ESCR) values in micro irrigation applications where pipes operate in exposed environments whilst carrying agricultural chemicals.

Medium Density PE(MDPE)

MDPE base resin is manufactured using a low pressure polymerization process, and the limited side branch chainstructure results in a material density range of 0.930-0.940 g/cm³.MDPE materials qualify as PE63 and PE80.

MDPE materials provide improved pipe properties when compared to the earlier high density materials used in pipes.

These properties include life, flexibility, ductility, slow crack growth resistance and crack propagation resistance. These properties of the MDPE materials are utilized in gas reticulation, small diameter pipe coils, travelling irrigator coils and water reticulation applications.

High Density PE (HDPE)

HDPE base resins are manufactured in a low pressure process, resulting in a chain structure with small side branches and a material density range of 0.930~0.960 g/cm³.HDPE materials qualify as PE80 and PE100 in accordance with ISO 4427.

HDPE materials are widely used in both pressure and non pressure applications such as water supply, liners, drains, outfalls, and sewers in pipe sizes up to1000 mm diameter. The increased stiffness of HDPE is used to advantage in such applications as electrical and communications conduits, sub-soild drainage, sewer and storm water.

Materials of VASEN PE Piping System

The VASEN PE piping systems are mainly produced with the specialized resin for pipe, whose trade name is BorSafe HE3490-LS from Borealis.

BorSafe HE3490-LS is a bimodal polyethylene compound produced by the advanced Borstar technology, which has outstanding UV resistance and long term stability.

BorSafe HE3490-LS is classified as an MRS 10.0 material (PE100).(shown as the following figure)

Bodycote Report

STANDARD EXTRAPOLATION METHOD(SEM)

SEM-evaluation according to ISO 9080:2003 of the PE pipe compound BorSafe™ HE3490-LS from Borealis AB

Joakim Jansson

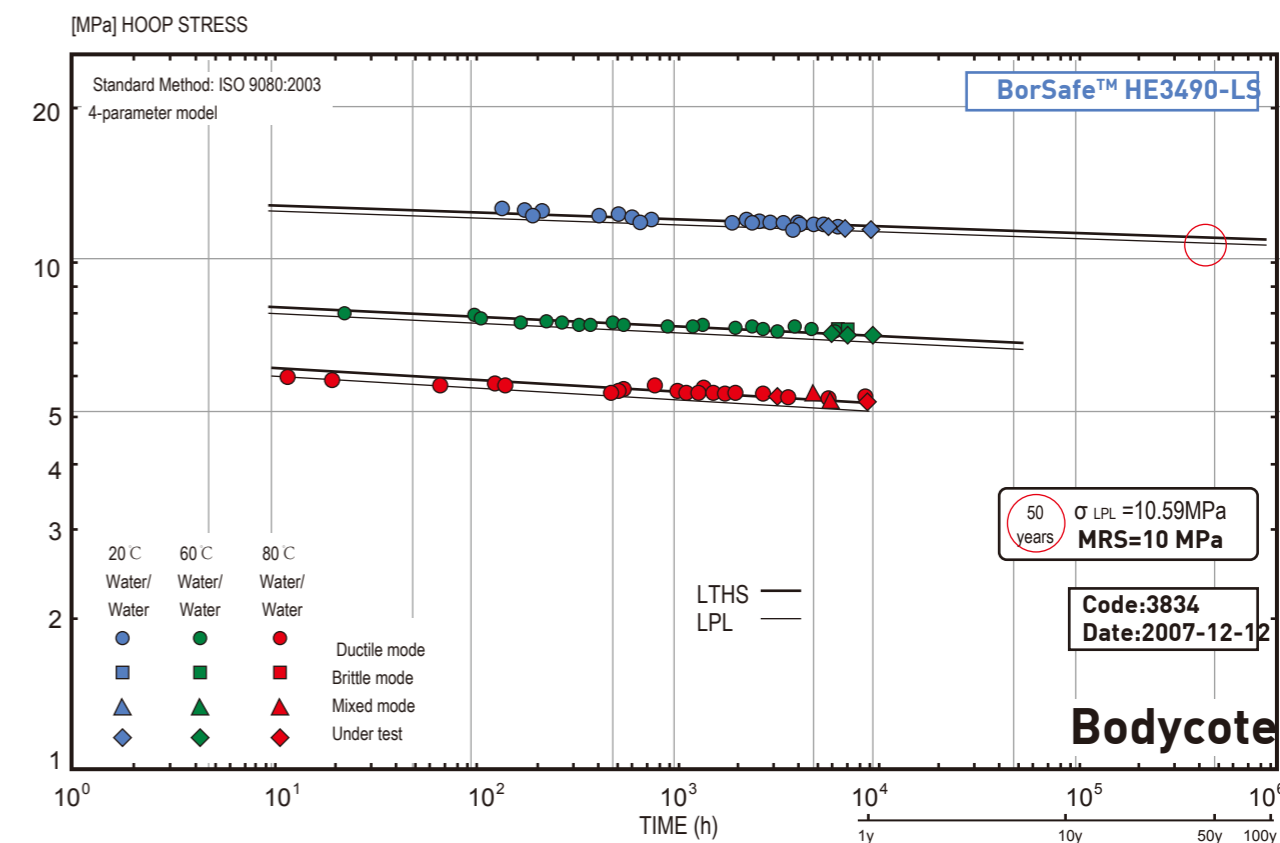

Section 4

Material Characteristics of PE100

The latest generations of high density PE pipe materials, known as high performance materials, are produced, for the most of the part, from bimodal resins. Modern PE100 resins usually show a bimodal molecular weight distribution, which consist of two different kinds of molecular chains (short and long). Pipes made from these materials are characterized by truly exceptional and unique resistance to slow crack growth (SCG), significantly improved long term performance, higher pressure ratings or increased flow capacity, and improved chemical resistance. In addition, the short molecular chains provide a good processability. PE also shows very high impact strength, even at low temperatures. A robust behavior like this, combined with a high elongation to break, is a big advantage in a lot of applications, e.g. in some regions that have a high risk of earthquakes.

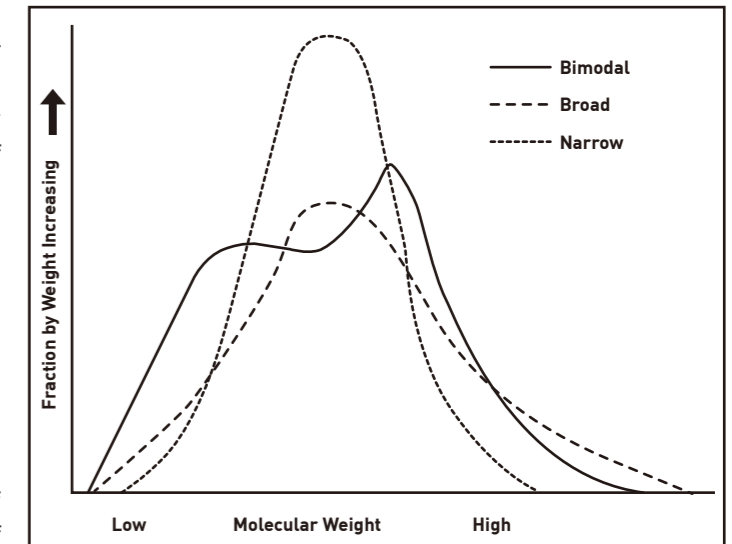

Typical values of the most commonly used mechanical properties are shown as following:

Table4. 1: Typical property of PE100 material

Property	Typical Value*	Test Method
Density (Compound)	959 kg/m ³	ISO 1872-2/ISO 1183
Melt Flow Rate (190 °C/5,0 kg)	0,25 g/10min	ISO 1133
Tensile Modulus (1 mm/min)	1100 MPa	ISO 527-2
Tensile Strain at Break	> 600%	ISO 527-2
Tensile Stress at Yield (50 mm/min)	25 MPa	ISO 527-2
Carbon black content	> 2 %	ASTM D 1603
Carbon black dispersion	<3	ISO 18553
Oxidation Induction Time (210 °C)	> 20 min	EN 728
Resistance to rapid crack propagation (S4 test, Pc at 0 °C, Test pipe 250 mm, SDR11)	> 10 bar	ISO 13477
Resistance to slow crack growth (9,2 bar, 80 °C)	> 1000 h	ISO 13479

*Typical values measured on the resin BorSafe HE3490-LS. These values should not be used for design purposes.

Section 5

Characteristics of VASEN PE Piping System

Abrasion Resistance

The transmission of solids in either liquid or gaseous carriers in PE pipelines results in abrasion of the internal pipe walls, especially at points of high turbulence such as bends or junctions. The high resistance to abrasion, flexibility, light weight, and robustness of VASEN PE pipes, has led to their wide usage in applications such as transportation of slurries and mine tailings.

Abrasion occurs as a result of friction between the pipe wall and the transported particles. The actual amount and rate of abrasion of the pipe wall is determined by a combination of:

- The specific gravity of the solids
- The solids content in the slurry
- Solid particle shape, hardness and size
- Fluid velocity
- PE pipe material grade

The results of some test programs show that, PE pipes have superior abrasion resistance to steel, ductile iron, FRP, asbestos and fiber reinforced cement pipes, providing a more cost effective solution for abrasive slurry installations.

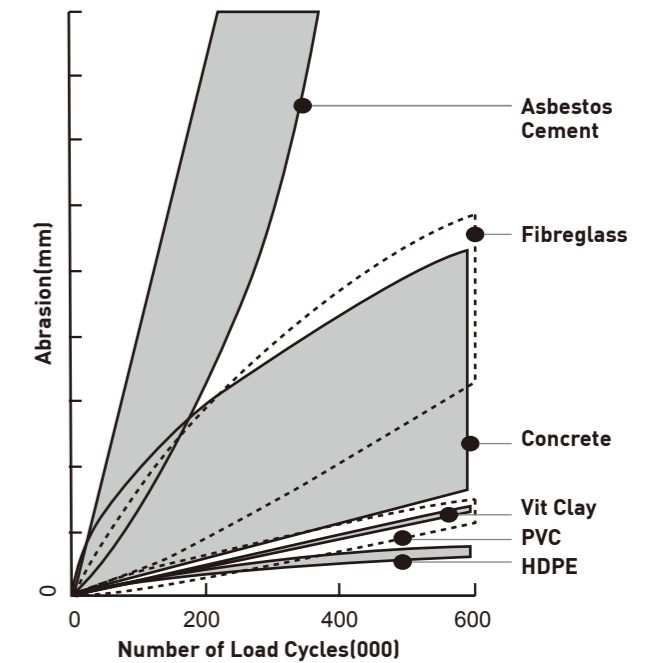

Chemical Resistance

VASEN HDPE pipe is suitable for many chemical solutions. Naturally occurring chemicals in the soil will not degrade the pipe. It is not an electrical conductor and does not rot, rust, or corrode by electrolytic action. It does not support the growth of algae, bacteria, or fungi and is resistant to marine biological attack. Gaseous hydrocarbons have no effect on expected service life. Liquid hydrocarbons will permeate the wall and reduce hydrostatic strength. When the hydrocarbon evaporates, the pipe will regain its original physical properties.

General effect of chemicals on VASEN HDPE pipe is shown as following:

- Resistant: water, solutions of inorganic salts, weak acids, strong organic acids, strong alkaline solutions, aliphatic hydrocarbons.
- Has adequate resistance: strong acids, hydrofluoric acids, fats and oils.
- Has limited resistance: lower alcohols, esters, ketones, ethers, aromatic hydrocarbons, mineral oil.
- In most cases non-resistant: light naphtha, fuel mixture.
- Completely non-resistant: unsaturated chlorinated hydrocarbons.

Table 5.1: Chemical resistance data of VASEN HDPE pipe

Legend: "S" -- Satisfactory "O" -- Some Attack "U" -- Unsatisfactory "NA" -- No Data Available					
	21 °C	60 °C		21 °C	60 °C
Acrylic Emulsions	S	S	Magnesium Chloride Saturated	S	S
Aluminum Chloride Dilute	S	S	Magnesium Hydroxide Saturated	S	S
Aluminum Chloride Concentrated	S	S	Magnesium Nitrate Saturated	S	S
Aluminum Fluoride Concentrated	S	S	Magnesium Sulfate Saturated	S	S
Aluminum Sulfate Concentrated	S	S	Mercuric Chloride	S	S
Ammonia 100% Dry Gas	S	S	Mercuric Cyanide Saturated	S	S
Ammonium Carbonate	S	S	Mercurous Nitrate Saturated	S	S
Ammonium Chloride Saturated	S	S	Methyl Ethyl Ketone 100%	U	U
Ammonium Fluoride 20%	S	S	Methyl Bromide	O	U
Ammonium Metaphosphate Saturated	S	S	Methylsulfuric Acid	S	S
Ammonium Persulfate Saturated	S	S	Methylene Chloride 100%	U	U
Ammonium Sulfate Saturated	S	S	Nickel Chloride Saturated	S	S
Ammonium Sulfide Saturated	S	S	Nickel Nitrate Concentrated	S	S
Ammonium Thiocyanate Saturated	S	S	Nickel Sulfate Saturated	S	S
Aniline 100%	S	NA	Nicotinic Acid	S	S
Antimony Chloride	S	S	Nitric Acid <50%	S	O
Barium Carbonate Saturated	S	S	Nitrobenzene 100%	U	U
Barium Chloride Saturated	S	S	Oleum Concentrated	U	U
Barium Sulfate Saturated	S	S	Oxalic Acid Dilute	S	S
Barium Sulfide Saturated	S	S	Oxalic Acid Saturated	S	S
Benzene Sulfonic Acid	S	S	Petroleum Ether	U	U
Bismuth Carbonate Saturated	S	S	Phosphoric Acid 0-30%	S	S
Black Liquor	S	S	Phosphoric Acid 90%	S	S
Borax Cold Saturated	S	S	Photographic Solutions	S	S
Boric Acid Dilute	S	S	Potassium Bicarbonate Saturated	S	S
Bromic Acid 10%	S	S	Potassium Borate 1 %	S	S
Bromine Liquid 100%	O	U	Potassium Bromate 10%	S	S
Butanediol 10%	S	S	Potassium Bromide Saturated	S	S
Butanediol 60%	S	S	Potassium Carbonate	S	S
Butanediol 100%	S	S	Potassium Chlorate Saturated	S	S

Table 5.1: Chemical resistance data of VASEN HDPE pipe

Legend: "S" -- Satisfactory "O" -- Some Attack "U" -- Unsatisfactory "NA" -- No Data Available					
	21 °C	60 °C		21 °C	60 °C
Butyl Acetate 100%	O	U	Potassium Chloride Saturated	S	S
Calcium Bisulfide	S	S	Potassium Chromate 40%	S	S
Calcium Carbonate Saturated	S	S	Potassium Cyanide Saturated	S	S
Calcium Chlorate Saturated	S	S	Potassium Ferri/Ferro Cyanide	S	S
Calcium Hypochlorite Bleach Solution	S	S	Potassium Fluoride	S	S
Calcium Nitrate 50%	S	S	Potassium Nitrate Saturated	S	S
Calcium Sulfate	S	S	Potassium Perborate Saturated	S	S
Carbon Dioxide 100% Dry	S	S	Potassium Perchlorate 10%	S	S
Carbon Dioxide 100% Wet	S	S	Potassium Permanganate 20%	S	S
Carbon Dioxide Cold Saturated	S	S	Potassium Sulfate Concentrated	S	S
Carbon Disulphide	NA	U	Potassium Sulfide Concentrated	S	S
Carbon Monoxide	S	S	Potassium Sulfite Concentrated	S	S
Chlorine Liquid	O	U	Potassium Persulfate Saturated	S	S
Chlorosulfonic Acid 100%	U	U	Propargyl Alcohol	S	S
Chromic Acid 50%	S	O	Propylene Glycol	S	S
Cider	S	S	Rayon Coagulating Bath	S	S
Coconut Oil Alcohols	S	S	Sea Water	S	S
Copper Chloride Saturated	S	S	Shortening	S	S
Copper Cyanide Saturated	S	S	Silicic Acid	S	S
Copper Fluoride 2%	S	S	Sodium Acetate Saturated	S	S
Copper Nitrate Saturated	S	S	Sodium Benzoate 35%	S	S
Copper Sulfate Dilute	S	S	Sodium Bisulfate Saturated	S	S
Copper Sulfate Saturated	S	S	Sodium Bisulfite Saturated	S	S
Cuprous Chloride Saturated	S	S	Sodium Borate	S	S
Cyclohexanone	U	U	Sodium Bromide Oil Solution	S	S
Dextrin Saturated	S	S	Sodium Bromide Oil Solution	S	S
Dextrose Saturated	S	S	Sodium Carbonate	S	S
Disodium Phosphate	S	S	Sodium Chlorate Saturated	S	S
Diethylene Glycol	S	S	Sodium Chloride Saturated	S	S
Emulsions Photographic	S	S	Sodium Cyanide	S	S

Table 5.1: Chemical resistance data of VASEN HDPE pipe

Legend: "S" -- Satisfactory "O" -- Some Attack "U" -- Unsatisfactory "NA" -- No Data Available					
	21 °C	60 °C		21 °C	60 °C
Ethyl Chloride	SO	U	Sodium Dichromate Saturated	S	S
Ferric Chloride Saturated	S	S	Sodium Ferricyanide Saturated	S	S
Ferric Nitrate Saturated	S	S	Sodium Ferrocyanide	S	S
Ferrous Chloride Saturated	S	S	Sodium Fluoride Saturated	S	S
Ferrous Sulfate	S	S	Sodium Nitrate	S	S
Fluoboric Acid	S	S	Sodium Sulfate	S	S
Fluorine	S	U	Sodium Sulfide 25% to Saturated	S	S
Fluosilicic Acid 32%	S	S	Sodium Sulfite Saturated	S	S
Fluosilicic Acid Concentrated	S	S	Stannous Chloride Saturated	S	S
Formic Acid 20%	S	S	Stannic Chloride Saturated	S	S
Formic Acid 50%	S	S	Starch Solution Saturated	S	S
Formic Acid 100%	S	S	Sulfuric Acid <50%	S	S
Fructose Saturated	S	S	Sulfuric Acid 96%	O	U
Fuel Oil	S	U	Sulfuric Acid 98% Concentrated	U	U
Glycol	S	S	Sulfurous Acid	S	S
Glycolic Acid 30%	S	S	Tannic Acid 10%	S	S
Hydrobromic Acid 50%	S	S	Tartaric Acid Saturated	NA	NA
Hydrocyanic Acid Saturated	S	S	Tetralin	U	U
Hydrochloric Acid 30%	S	S	Tetrahydrofuran	O	O
Hydrofluoric Acid 40%	S	S	Transformer Oil	S	O
Hydrofluoric Acid 60%	S	S	Trichloroacetic Acid 10%	S	S
Hydrogen 100%	S	S	Trisodium Phosphate Saturated	S	S
Hydrogen Bromide 10%	S	S	Urea	S	S
Hydrogen Chloride Gas Dry	S	S	Urine	S	S
Hydroquinone	S	S	Wetting Agents	S	S
Hydrogen Sulfide	S	S	Xylene	U	U
Hypochlorous Acid Concentrated	S	S	Zinc Chloride Saturated	S	S
Lead Acetate Saturated	S	S	Zinc Sulfate Saturated	S	S

Flexibility

The flexibility of polyethylene pipe allows it to be curved over, under, and around obstacles as well as make elevation and directional changes. In some instances, the pipe's flexibility may remarkably eliminate the usage of fittings and greatly reduce installation costs.

VASEN PE pipe can be bent to a minimum radius between 20 to 40 times the diameter of pipe, which mainly depends on the SDR of the certain pipe.

Table 5.2: Minimum allowable bend radius of HDPE pipe at 23 °C

SDR of the pipe	Minimum allowable bend radius, R_{min}
6	$R_{min} > 20 \times d_n^*$
7.4	$R_{min} > 20 \times d_n^*$
9	$R_{min} > 20 \times d_n^*$
11	$R_{min} > 25 \times d_n^*$
13.6	$R_{min} > 25 \times d_n^*$
17	$R_{min} > 27 \times d_n^*$
21	$R_{min} > 28 \times d_n^*$
26	$R_{min} > 35 \times d_n^*$
33	$R_{min} > 40 \times d_n^*$

* d_n : is the nominal outside diameter, in millimeters

Light Weight

The density of PE material is only 1/7 of that of steel. The weight of PE pipe is much less than that of concrete, cast iron, or steel pipe. The PE piping system is easy to handle and install, and reduced manpower and equipment requirements may result in installation savings.

Life Expectancy

The hydrostatic design basis for VASEN pipe is based on extensive hydrostatic testing data evaluated by standardized industry methods. The long-term behavior for internal pressure resistances provided by the hydrostatic strength curve based on the EN ISO 15494 standard (see section X). The application limits for pipes and fittings, as shown in the pressure-temperature diagram, can be derived from these curves, which show that the pipe has a life expectancy of approximately 50 years when transporting water at 20 °C. Internal and external environmental conditions may alter the expected life or change the recommended design basis for a given application.

Weathering Resistance

Weathering of plastics occurs by a process of surface degradation, or oxidation, due to a combined effect of ultra violet radiation, increased temperature, and moisture when pipes are stored in exposed locations. Black polyethylene pipe, containing 2 to 2.5% finely divided carbon black, can be safely stored outside in most climates for many years without damage from ultra-violet exposure. Carbon black is the most effective single additive to enhance the weathering characteristics of plastic materials. Other colors such as white, blue, yellow or lilac do not possess the same stability as the black pigmented systems and the period of exposure should be limited to one year for optimum retention of properties. With these color systems the external surface oxidation layers develop at a faster rate than those in carbon black stabilized PE pipes. These colored pipes are not recommended for above ground applications.

Thermal Properties

Polyethylene pipes can be used at temperatures ranging from -50°C to $+60^{\circ}\text{C}$. At higher temperatures, the tensile strength and stiffness of the material are reduced. Therefore, please consult the pressure-temperature diagram. For temperatures below 0°C it must be ensured that the medium does not freeze, to avoid consequently damage to the piping system.

Like all thermoplastics, PE shows a higher thermal expansion than metal. Our PE has a coefficient of linear thermal expansion of 0.15 to 0.20 mm/m K, which is 1.5times greater than that of e. g. PVC. As long as this is taken into account during the planning of the installation, there should be no problems in this regard.

The thermal conductivity is 0.38 W/m K. Because of the resulting insulation properties, a PE piping system is notably more economical in comparison to a system made of a metal material like copper.



Combustion Behavior

Polyethylene belongs to the flammable plastics. The oxygen index amounts to 17 %. (Materials that burn with less than 21 % of oxygen in the air are considered to be flammable).

PE drips and continues to burn without soot after removing the flame. Basically, toxic substances are released by all burning processes. Carbon monoxide is generally the combustion product most dangerous to humans. When PE burns, primarily carbon dioxide, carbon monoxide and water are formed.

The self-ignition temperature is 350°C .

Suitable fire-fighting agents are water, foam, carbon dioxide or powder.

Biological Resistance

PE pipes may be subject to damage from biological sources such as ants or rodents. The resistance to attack is determined by the hardness of the PE used, the geometry of the PE surfaces, and the conditions of the installation. In small diameter pipes, the thin wall sections may be damaged by termites in extreme cases. However damage often ascribed to termite attack in PE has subsequently been found to be due to other sources of mechanical damage.

PE pipe systems are generally unaffected by biological organisms in both land, and marine applications, and the paraffinic nature of the PE pipe surfaces retards the buildup of marine growths in service.

Electrical Properties

Because of the low water absorption of PE, its electrical properties are hardly affected by continuous water contact. Since PE is a non-polar hydrocarbon polymer, it is an outstanding insulator. These properties, however, can be worsened considerably as a result of pollution, effects of oxidizing media or weathering. The specific volume resistance is $>10^{17}\ \Omega\ \text{cm}$; the dielectric strength is 220 kV/mm.

Because of the possible development of electrostatic charges, caution is recommended when using PE in applications where the danger of fires or explosion is given.

Section 6

Applications of VASEN PE Piping System

The successful and continued high level of growth in the application of polyethylene for piping systems has not come about by chance. Polyethylene systems offer significant advantages over 'traditional' iron, steel and cement systems.

And VASEN PE piping system has such principal advantages as following:

- Flexibility
- Chemical resistance
- Fusion welded jointing
- Resistance to ground movement and end load
- Effective installation techniques
- High impact strength
- Abrasion resistance
- High flow capacity
- Weathering resistance
- Low whole life costs
- Long lengths pipeline

Based on these advantages, VASEN PE piping system can be applied in the following fields.

Water supply in cities and counties



- Long-life service
- Good corrosion resistance
- Excellent sanitary property, supplying high quality water

Gas distribution



- Flexibility
- Long-life service
- Corrosion resistance

Storm water drainage



- Superior flow characteristics
- Lightweight
- Corrosion resistance

HVAC – Heating, Ventilation, and Air Conditioning



VASEN PE piping system for GSHP(Ground Source Heat Pump) application

- Long-life service
- Good thermal conductivity
- Flexibility
- Long length in coils

Drainage system in buildings



- Easy installation
- Water tightness
- Silencing effect

Above ground pipelines



PE pipe is widely used in above ground applications, particularly in demanding conditions typical of mining and rural regions.

- Ultra-violet (UV) resistance
- High impact strength

Relining & Rehabilitation for original piping system



Slip lining and pipe bursting with long length of PE pipes provide minimal disruption to existing water and sewer systems and the local community.

- Long length and minimal disruption
- Corrosion resistance
- Flexibility

Industrial & chemical pipelines



PE piping systems can be installed in difficult to access kinds of industrial situations, which is because:

- A range of connection solutions
- Excellent chemical resistance

Submarine pipelines



Water supply project in TOUMEN port of Taizhou in 2014 by VASEN

- Light weight
- Corrosion resistance to sea water
- Superior flow characteristics

Pipelines for ships



Now, VASEN PE pipes and fittings are widely used in kinds fields of ships

- Light weight
- Corrosion resistance to sea water
- A range of connection solutions in narrow space

Aquaculture – fish cages



- Light weight
- Corrosion resistance to sea water
- Superior flow characteristics

Section 7

Design of the System

Material Classification According to Mrs

Long-term behavior characteristics of pressurized plastic pipes are differentiated in a standard classification system. As a basis for this classification long-term pressure diagrams are created and extrapolated. In the determination of the long-term hydrostatic strength of PE 100 materials in accordance with ISO 9080, the detection of a knee on the 80 ° C extrapolation curve before 5000 h is unacceptable. The maximum stress depending on time at a constant temperature is determined. The expected value LTHS (Long Term Hydrostatic Strength) describes the theoretical curve of the measured test data. Using the lower confidence limit (LCL) the statistical spread of measurements is buffered (LCL = 97.5% LTHS), see figure 7.1. The classification of the compound in accordance with ISO 9080 shall be certified by the compound producer.

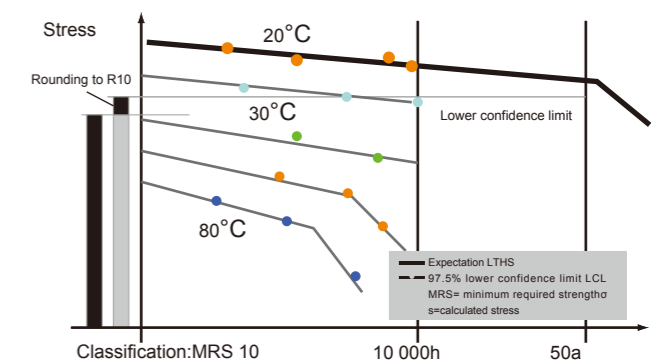

Figure 7.1

The stress at 50 years, determined this way (rounded to the nearest lower standard value) results in the MRS-value (Minimum Required Strength), the material-specific minimum strength, in accordance with Table 7.1.

Table 7. 1 – Material designation and corresponding maximum design stress values

Classification of PE materials

Type of Material	Minimum required strength(MRS) MPa	σ_s MPa
PE 100	10.0	8.0
PE 80	8.0	6.3
Design stress, σ_s , is derived from the MRS by application of the overall service (design) coefficient, C=1.25.		

NOTE: Where fittings are manufactured from the same compound as the pipe, then the material classification will be the same as the pipe.

When a compound is intended only to be used for the manufacture of fittings, the compound shall be classified using test pieces prepared in accordance with ISO 1167-2.

Long-term Behavior of Thermoplastic Material

The most important characteristic of pressurized plastics is the pressure-time-behavior. This means the empirical and calculated life-time of pipes and parts of piping systems under depending boundary conditions such as inner pressure, temperature and time. The allowable stresses are always to be regarded dependent in contrast to metallic parts. By increasing the temperature during testing it becomes possible to conclude on longtime-behavior at 20°C based on short-term tests.

The following picture shows the long-term behavior of PE 100 according to EN ISO 15494:2003.

Minimum prediction hydrostatic strength in temperature range of 10 °C to 80 °C can be referred from the curve shown in figure 7.2, which can be deduced from the following equation:

$$\text{Log}(t) = C_1 + C_2 \cdot \left(\frac{1}{T}\right) + C_3 \cdot \text{Log}(\sigma) + C_4 \cdot \frac{\text{Log}(\sigma)}{T}$$

Where:

t - Time to failure(h)

T-Temperature(K)

σ -Hoop stress(MPa)

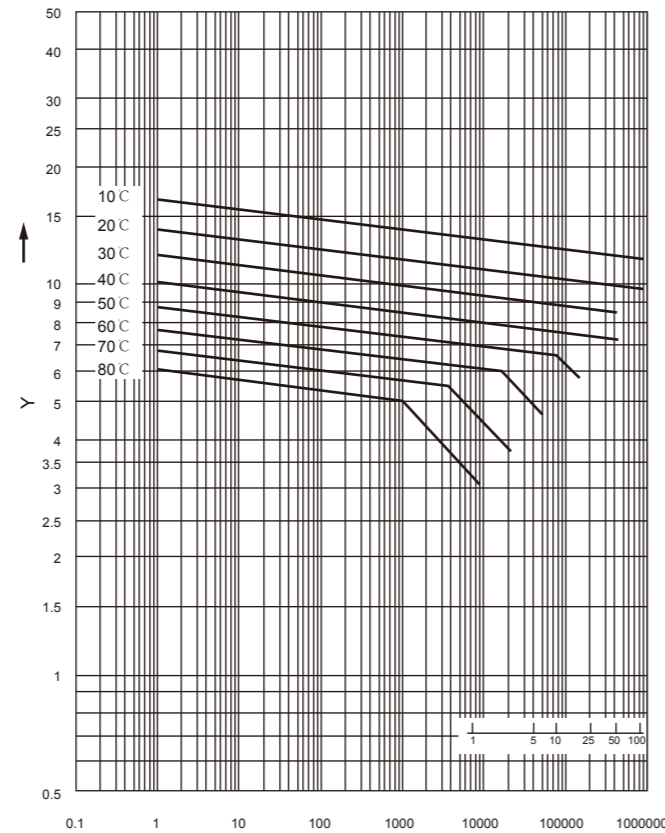

Figure 7.2

Y -Stress in Mega Pascal (MPa) / 1MPa = 1 N/mm²

X -Time to failure (h)

a –years

Table 7.2 –Regression coefficients of BorSafe™HE3490-LS for the 4-parameter model

	C ₁	C ₂	C ₃	C ₄
Value	-144.415	62717.820	61.930	-36238.859

Note: These coefficients are only valid for the investigated pipe grade BorSafe™HE3490-LS with Bodycote internal code 3834.

Pressure Reduction Coefficients

When a PE piping system is to be operated at a continuous constant temperature higher than 20 °C and up to 40 °C, a pressure reduction coefficient as given in Table 7.3 may be applicable for PE 80 and PE 100.

Table 7.3 — Pressure reduction coefficients for PE 80 and PE 100

Temperature ^{a,b} °C	Coefficient
20	1.00
25	0.92
30	0.85
35	0.79
40	0.73

NOTE: Unless analysis according to ISO 9080 demonstrates that less reduction is applicable, in which case higher factors and hence higher pressures may be applied

a for other temperature between each step, interpolation is permitted(see also ISO 13761)
b for higher temperatures, consult the compound manufacturer

NOTE: The allowable operating pressure (PFA) is derived from the following equation:

$$\text{PFA} = f_T \times f_A \times \text{PN}$$

Where

f_T -the coefficient according to Table 7.3;

f_A -the derating factor (or uprating factor) related to the application (for the conveyance of water f_A=1);

PN -the nominal pressure

Relationship Between PN, MRS, S and SDR

The relationship between nominal pressure, PN, design stress, σ_s , and the series S/SDR is given by the following equation:

$$PN = \frac{10\sigma_s}{S} \quad \text{or} \quad PN = \frac{20\sigma_s}{SDR-1}$$

Examples of the relationship between PN, MRS, S, and SDR based on

$$\sigma_s = \frac{MRS}{C}$$

are given in Table2, where C =1.25.

NOTE: The nominal pressures (PN) given in Table 7.4 are based on the use of an overall design coefficient of C=1.25. However, if a higher value for C is required, the PN values will have to be recalculated using the above equations and based on the calculated design stress, σ_s , for each material class. A higher value for C can also be obtained by choosing a higher PN class.

Table 7.4-Nominal pressure for material class(bar)

SDR	S	Nominal pressure for material class (bar)	
		PE 80	PE 100
41	20	3.2	4
33	16	4	5
26	12.5	5	6a
21	10	6a	8
17	8	8	10
13.6	6.3	10	12.5
11	5	12.5	16
9	4	16	20
7.4	3.2	20	25
6	2.5	25	-

NOTE 1 bar=0.1MPa=105Pa; 1 MPa=1 N/mm²

Actual calculated values are 6.4 bar for PE 100 and 6.3 bar for PE 80 and PE 63

Calculation of Allowed Pressure/Wall Thickness

The technical design of pressurized thermoplastic pipes is carried out strictly according to strength requirements by means of the KESSEL formula. All pipe dimensions in standards are based on this formula. Deviations are just possible in smaller diameters since certain wall thicknesses will not under-run be due to practical and production limitations.

$$e = \frac{pd}{20\sigma_{zul} + p}$$

Using:

e -wall thickness in mm

d -outer pipe diameter in mm

p -allowable pressure in bar

σ_{zul} -allowable stress in N/mm²

Simply using the nominal pressure is not enough any more. The usual deployment of PN as a measure for the pipe size can harbor a danger of confusion regarding butt fusion. Plastic pipes and fittings equally pressure tolerable are meanwhile marked pressure-neutrally. The goal is to prevent a misuse of pipes in different application areas or different conditions. According to ISO 4065 pipes are classified into series. The series determines the load resistance without possibility of confusion as the nominal pressure did. The pipe series is marked by the letter S. This series is based on the following formula:

$$S = \frac{10\sigma_{zul}}{pc} = \frac{d - e}{2e}$$

Consequently, S is dimensionless. For a PE pipe with the dimensions 200 x 18.2 mm the formula yields

$$S = 5 = (200 - 18.2) / (2 \times 18.2).$$

Further the denotation SDR is known. SDR stands for Standard Dimension Ratio. SDR indicates the diameter/wall-thickness-ratio:

$$SDR = \frac{d}{e}$$

Series and SDR are connected through the following formula: $SDR = 2 \times S + 1$ or $S = (SDR-1) / 2$.

Using the upper example:

$$SDR = \frac{200}{18.2} = 11 = 2 \times 5 + 1$$

Currently all three indicators PN, S and SDR are used in the market. VASEN recommends to always state dimension, wall-thickness and pipe series or SDR.

Calculation of Design Factor

To calculate design factor and allowable operating pressure it is necessary to know the creep strength of the material. Depending on expected useful life and the max operating temperature this diagram contains the value of the creep strength σ . Since the wall thicknesses of fittings and valves are higher compared to pipes due to the shape of the parts, it is necessary to base the calculation upon outer diameter and wall thickness of a pipe of the same pressure rating. The effective design factor can be calculated using the following formula:

$$C = \frac{\sigma_s \times 20 \times e}{P(d - e)}$$

The following example is based on the previously used numbers. In this case the usual minimum value of design factor of PE100 is applied.

$$P_{\max} = \left(\frac{20 \times 18.2 \times 10}{1.25 \times (200 - 18.2)} \right) = 16 \text{ bar}$$

Remark: The previously described calculation is only valid for freely moving pipelines. Axially fixed pipes have to be checked for buckling. In most of the cases, this examination leads to a reduction of the maximum inner pressure and shorter distances between the support brackets. Further, locally applied forces at fixed points have to be considered. For assistance, please contact your nearest VASEN representative.

Max. allowable pressure for PE-pipes

C	Design Factor	Material	SDR 17	SDR 11
	Water	PE80	8	12.5
	1.25	PE100	10	16

Calculation of Elongation

The following formula describes the temperature-dependent elongation:

$$\Delta L = L \times \Delta T \times \alpha$$

With:

- ΔL = temperature dependent elongation (mm)
- L = pipe length (m)
- ΔT = temperature difference (K)
- α = linear expansion coefficient (mm/ (m. K))

Some expansion coefficients of polymer materials:

Material	α = mm/(m. K)
PE	0.15-0.20
PP	0.16-0.18
PVC-U	0.07-0.08

Important: A higher working temperature compared to the installation temperature results in an elongation of the pipe. A lower working temperature results in a shorter pipe.

Consequently: Installation temperature, minimum and maximum working temperature have to be considered.

1. Pipe at installation temperature
2. Working temperature above installation temperature
3. Working temperature below installation temperature

An elongation of the pipe is denoted by "+" a shortage by "-"

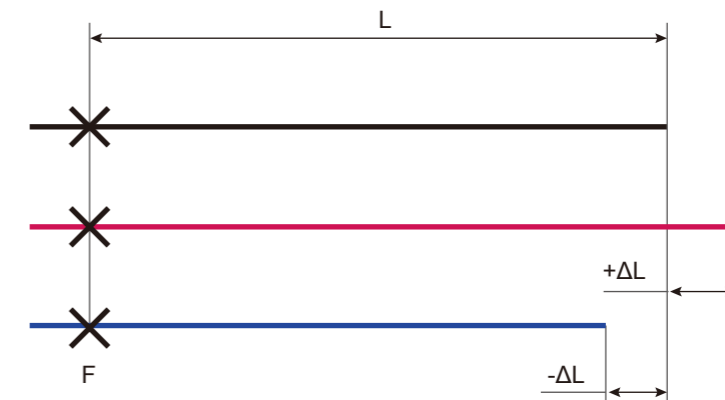

Water Hammer

Water hammer, or surge pressure, is a term used to describe dynamic surges caused by pressure changes in a piping system. They occur whenever there is a deviation from the steady state, i.e. when the velocity of the fluid is increased or decreased, and may be transient or oscillating. Waves of positive or negative pressure may be generated by any of the following:

- opening or closing of a valve
- pump startup or shutdown
- change in pump or turbine speed
- wave action in a feed tank
- entrapped air

The pressure waves travel along at speeds limited by the speed of sound in the medium, causing the pipe to expand and contract. The energy carried by the wave is dissipated and the waves are progressively damped (see Figure).

The pressure excess to water hammer must be considered in addition to the hydrostatic load, and this total pressure must be sustainable by the piping system. In case of oscillatory surge pressures extreme caution is needed as surging at the harmonic frequency of the system leads to catastrophic damages.

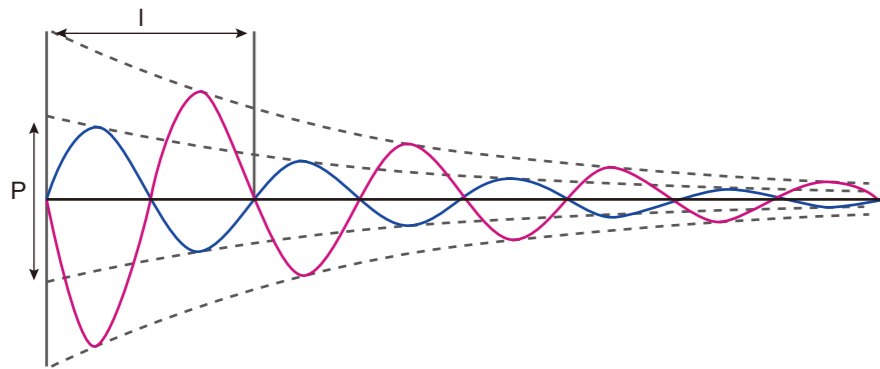

Damped pressure wave

l -Wavelength

P -Pressure change

PE pipes are able to take water hammers relatively well as long as the mean stress is not bigger than the stress executed by the maximum allowable operating pressure.

For example a PE pipe SDR 17 having a maximum operating pressure of 10 bar is able to take a pressure amplitude of 0 to 20 bar. The pressure amplitude for water at 20 ° C and PE pipe is calculated using the following formulas (Differentiation of the Joukowsky-Formula):

$$P_s = \pm \frac{14.49}{\sqrt{1 + \frac{1.25 \times d_n \times e_n}{e_n}}} v_c$$

P_s -pressure amplitude in bar

v_c -flow velocity of the water in m/s

d_n -pipe outer diameter in mm

e_n -wall thickness of the pipe in mm

Pressure Loss

Top-level Quality Assurance Systems

When calculating the pressure loss in straight pipe lengths there is a distinction between laminar and turbulent flow. The important unit of measurement is the Reynold's number (Re). The changeover from laminar to turbulent flow occurs at the critical value, Reynold' s number (Re) = 2320.

Laminar flow occurs, in practice, particularly in the transport of viscous media, i. e. lubricating oil. In the majority of applications, including media similar to water, a turbulent flow, having an essentially steady velocity in a cross-section of pipe, occurs.

The pressure loss in a straight length of pipe is inversely proportional to the pipe diameter and is calculated by the following formula:

$$\Delta p_R = \lambda \frac{L}{d_i} \frac{\rho}{2 \times 10^2} v^2$$

NOTE: In practice, when making a rough calculation (i. e. smooth plastic pipe and turbulent flow) it is enough to use the value $\lambda = 0.02$ to represent the hydraulic pressure loss.

where:

Δp_R -pressure loss in a straight length of pipe in bar

λ -pipe friction factor

L -length of the straight length of pipe in m

d_i -inside diameter of pipe in mm

ρ -density of transported media in kg/m³ (1 g/cm³ = 1000 kg/m³)

v -flow velocity in m/s

Pressure Loss In Fittings

Coefficient of resistance

The pressure losses depend upon the type of fitting as well as on the flow in the fitting. The so-called ζ -value is used for calculations.

Fitting type	Coefficient of resistance ζ	
90° bend	Bend radius R	ζ -value
	1.0*d	0.52
	1.5*d	0.43
	2.0*d	0.36
45° bend	Bend radius R	ζ -value
	1.0*d	0.37
	1.5*d	0.25
	2.0*d	0.25
90° elbow	1.2	
45° elbow	0.3	
Tee 90°	1.3	
Reduction(Contraction)	0.5	
Reduction(Extension)	1.0	
Connection (Flange, union, welding between two pipes)	d > 90 mm: 0.1	
	20 ≤ d ≤ 90 mm: 1.0 to 0.1	
	d20: 1.0 d25: 0.9 d32: 0.8 d40: 0.7	
	d50: 0.6 d63: 0.4 d75: 0.3 d90: 0.1	

For a more detailed view differentiate between coalescence and separation. Values for ζ up to a maximum of 1.3 can be found in the respective literature. Usually the part of a tee in the overall pressure loss is very small, therefore in most cases $\zeta = 1.3$ can be used.

Calculation of the pressure loss

To calculate the total pressure loss in all fittings in a pipeline take the sum of the individual losses, i. e. the sum of all the ζ -values. The pressure loss can then be calculated according to the following formula:

$$\Delta p_{Fi} = \sum \zeta \frac{v^2}{2 \times 10^5} \rho$$

Where:

Δp_{Fi} - pressure loss in all fittings in bar

$\sum \zeta$ - sum of the individual losses

v - flow velocity in m/s

ρ - density of the transported medium in kg/m³ (1 g/cm³ = 1000 kg/m³)

Pressure Loss In Valves

The kv factor is a convenient means of calculating the hydraulic flow rates for valves. It allows for all internal resistances and for practical purposes is regarded as reliable.

The kv factor is defined as the flow rate of water in liters per minute with a pressure drop of 1 bar across the valve. The technical datasheets for valves supplied by GF contain the so-called kv values as well as pressure loss diagram. The latter make it possible to read off the pressure loss directly. But the pressure loss can also be calculated from the kv value according to the following formula:

$$\Delta p_{Ar} = \left(\frac{Q}{k_v} \right)^2 \cdot \frac{\rho}{1000}$$

Where:

Δp_{Ar} - pressure loss of the valve in bar

Q - flow rate in m³/h

ρ - density of the medium transported in kg/m³ (1 g/cm³ = 1000 kg/m³)

k_v - valve flow characteristic in m³/h.

Pressure Difference Caused By Static Pressure

Compensation for a geodetic pressure difference may be necessary when a pipeline is vertically installed. The pressure difference can be calculated with the following formula:

$$\Delta p_{geod} = \Delta H_{geod} \cdot \rho \cdot 10^{-4}$$

Where:

Δp_{geod} - geodetic pressure difference in bar

ΔH_{geod} - difference in elevation of the pipeline in m

ρ - density of media kg/m³ (1 g/cm³ = 1000 kg/m³)

Sum of pressure losses

The sum of all the pressure losses in the pipeline is then given by

$$\sum \Delta p = \Delta p_R + \Delta p_{Fi} + \Delta p_{Ar} + \Delta p_{geod}$$

Section 8

Connection Methods

General Provisions

The diameter of VASEN PE pipes ranges from 20 mm to 1200 mm, and there are many types and styles of fittings available for customers to choose. PE pipes or fittings are joined to each other by heat fusion or with mechanical fittings.

PE pipe also can be joined to other material pipes by means of compression fittings, flanges, or other qualified types of manufactured transition fittings.

Each offer sits particular advantages and limitations for each joining situation the user may encounter. Contact with the various manufacturers is advisable for guidance in proper applications and styles available for joining as described in this document as following.

Connection Methods

There are several types of conventional heat fusion joints currently used in the industry: Butt, Saddle, and Socket Fusion. Additionally, electrofusion (EF) jointing is available with special EF couplers and saddle fittings.

The principle of heat fusion is to heat two surfaces to a designated temperature, then fuse them together by application of a sufficient force. This force causes the melted materials to flow and mix, thereby resulting in fusion. When fused according to the pipe and/or fitting manufacturers' procedures, the joint area becomes as strong as or stronger than, the pipe itself in both tensile and pressure properties and properly fused joints are absolutely leak proof. As soon as the joint cools to near ambient temperature, it is ready for handling. The following sections of this chapter provide a general procedural guideline for each of these connection methods.

Butt fusion

Butt fusion is the most widely used method for joining individual lengths of PE pipes and pipes to PE fittings, which is by heat fusion of the pipe butt ends as illustrated in Figure 8.2.1.A. This technique produces a permanent, economical and flow-efficient connection. High-quality butt fusion joints are produced by trained operators in good condition.



Figure 8.2.1.A

Butt fusion is generally applied to PE pipes within the size range 63 mm to 1200 mm for joints on pipes, fittings and end treatments. Butt fusion provides a homogeneous joint with the same properties as the pipe and fittings materials, and ability to resist longitudinal loads.

The butt fusion process consists of the following steps which are shown in principle in the figure below and describe as following procedures.(See Figure 8.2.1B)

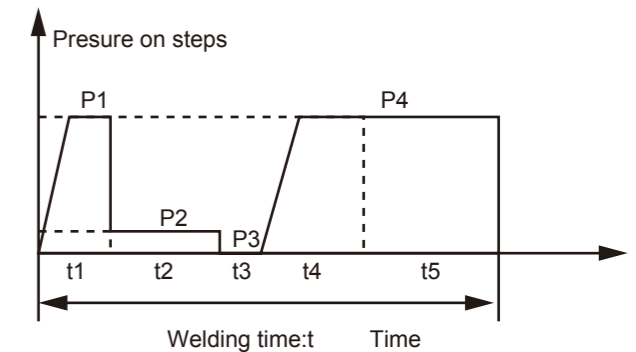

Figure 8.2.1.B Principle of Butt fusion of PE pipes

P1 is the pressure of "Pre-welding Step" (t1),
 $P1 = P_w(\text{welding pressure}) + P_d(\text{drag pressure})$;
 P2 is the pressure of "Heat-absorption Step" (t2),
 $P2 = P_d$;
 P3 is 0 in the "Switching Step" (t3, as soon as possible);
 P4 is the pressure of "Welding Step" (t4) and "Cooling Step" (t5), $P4 = P1$.

Butt fusion steps

1. The pipes must be installed in the welding machine, and the ends cleaned with non depositing alcohol to remove all dirt, dust, moisture, and greasy films from a zone approximately 70 mm from the end of each pipe, on both inside and outside diameter faces.



2. The ends of the pipes are trimmed using a rotating cutter to remove all rough ends and oxidation layers. The trimmed end faces must be square and parallel.



3. The ends of the PE pipes are heated by connection under pressure (P_1) against a heater plate. The heater plates must be clean and free from contamination, and maintained within a surface temperature range ($210 \pm 5^\circ\text{C}$ for PE80, $225 \pm 5^\circ\text{C}$ for PE100). Connection is maintained until even heating is established around the pipe ends, and the connection pressure then reduce to a lower value P_2 ($P_2 = P_d$). Connection is then maintained until the "Heat-absorption Step" ends.



4. The heated pipe ends are then retracted and the heater plate removed as soon as possible (t_3 : no contact pressure).

5. The heated PE pipe ends are then brought together and pressurized evenly to the welding pressure value ($P_4 = P_1$). This pressure is then maintained for a period to allow the welding process to take place, and the fused joint to cool down to ambient temperature and hence develop full joint strength. ($t_4 + t_5$). During this cooling period the joints must remain undisturbed and under compression. Under no circumstances should the joints be sprayed with cold water. The combinations of times, temperatures, and pressures to be adopted depends on the PE material grade, the diameter and wall thickness of the pipes, and the brand and model of fusion machine being used. VASEN engineers can provide guidance in the separate meters, which are listed in the following forms:

SDR	SIZE	P_w	ew^*	t_2	t_3	t_4	P_4	t_5
	(mm)	(MPa)	(mm)	(s)	(s)	(s)	(MPa)	(min)
SDR17	D110*6.6	321/S ₂	1.0	66	6	6	321/S ₂	9
	D125*7.4	410/S ₂	1.5	74	6	6	410/S ₂	12
	D160*9.5	673/S ₂	1.5	95	7	7	673/S ₂	13
	D200*11.9	1054/S ₂	1.5	119	8	8	1054/S ₂	16
	D225*13.4	1335/S ₂	2.0	134	8	8	1335/S ₂	18
	D250*14.8	1640/S ₂	2.0	148	9	9	1640/S ₂	19
SDR13.6	D315*18.7	2610/S ₂	2.0	187	10	10	2610/S ₂	24
	D110*8.1	389/S ₂	1.5	81	6	6	389/S ₂	11
	D125*9.2	502/S ₂	1.5	92	7	7	502/S ₂	13
	D160*11.8	824/S ₂	1.5	118	8	8	824/S ₂	16
	D200*14.7	1283/S ₂	2.0	147	9	9	1283/S ₂	19
	D225*16.6	1629/S ₂	2.0	166	9	10	1629/S ₂	21
SDR11	D250*18.4	2007/S ₂	2.0	184	10	11	2007/S ₂	23
	D315*23.2	3189/S ₂	2.5	232	11	13	3189/S ₂	29
	D110*10	471/S ₂	1.5	100	7	7	471/S ₂	14
	D125*11.4	610/S ₂	1.5	114	8	8	610/S ₂	15
	D160*14.6	1000/S ₂	2.0	146	9	9	1000/S ₂	19
	D200*18.2	1558/S ₂	2.0	182	10	11	1558/S ₂	23
	D225*20.5	1975/S ₂	2.5	205	11	12	1975/S ₂	26
D250*22.7	2430/S ₂	2.5	227	11	13	2430/S ₂	28	
D315*28.6	3858/S ₂	3.0	286	13	15	3858/S ₂	35	

ew^* is the height of the welding bead at the fusion connection.

The final weld beads should be fully rolled over, free from pitting and voids, correctly sized, and free from discolouration. When correctly performed, the minimum long term strength of the butt fusion joint should be 90% of the strength of the parent PE pipe.

The parameters of the welding connection should conform to the demands in Figure 8.2.1.B

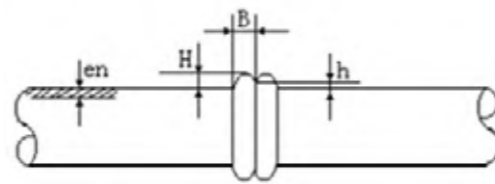

Normally:
 $B=0.35 \sim 0.45en$
 $H=0.2 \sim 0.25en$
 $h=0.1 \sim 0.2en$

Figure 8.2.1.B

Note: Following fusion results should be avoided:

Over-welding: welding rings are too wide



Unfitness butt fusion: the two pipes are not in alignment

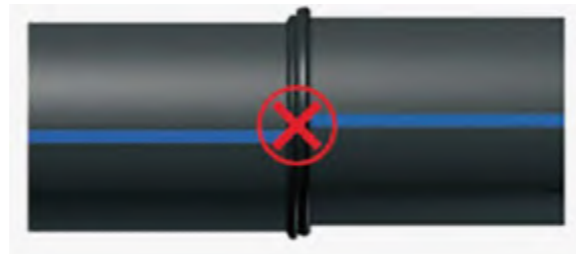

Dry-welding: welding rings are too narrow, usually due to low temperature or shortage of pressure



Incomplete curling: welding temperature is too low

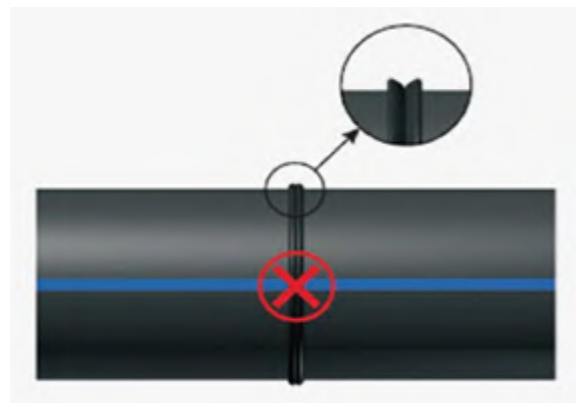

Socket Fusion

For the PE pipes and fittings which have rather small diameters (from 20mm to 63mm), socket fusion is a kind of convenient method. This technique consists of simultaneously heating both the external surface of the pipe end and the internal surface of the socket fitting until the material reaches the recommended fusion temperature, inspect the melt pattern, insert the pipe end into the socket, and hold it in place until the joint cools. Figure below illustrates a typical socket fusion joint.

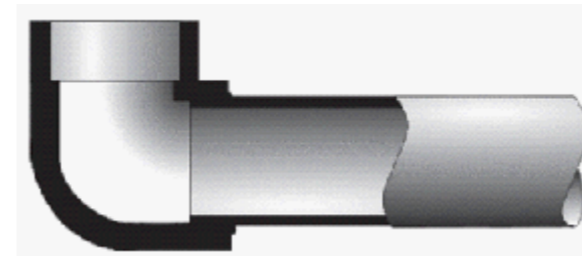

The heater elements are coated by PTFE, and must be kept clean and free from contamination at all times. The heater tools need to be set and calibrated to maintain a stable surface temperature range from 240 °C to 260 °C, which depends on the diameter of the pipe. All jointing must be performed under cover to prevent contamination of the joints from dust, dirt, or moisture.

The procedure of socket fusion

1. Cut the pipes, clean the spigot section with a clean cloth and a non-depositing alcohol to the full depth of the socket. Mark the length of the socket. Clean the inside of the socket section.



2. Scrape the outside of the pipe spigot to remove the outside layer from the pipe. Do not scrape the inside of the sockets.

3. Confirm the temperature of the heating elements, and ensure that the heating surfaces are clean.

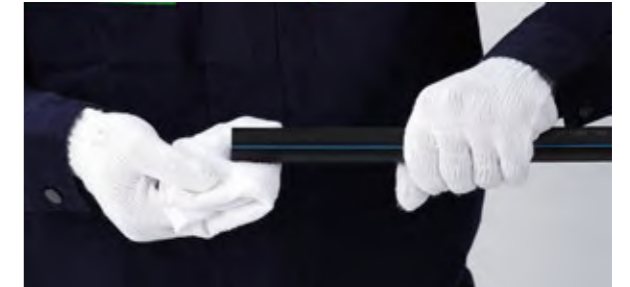

4. Push the spigot and socket sections on to the heating elements to the full length of engagement, and allow to heat for the appropriate period. See Table 8.2.2

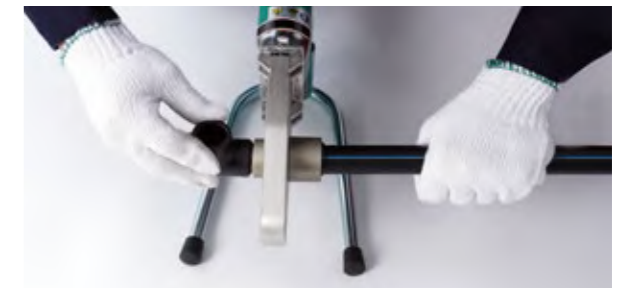

5. Pull the spigot and socket sections from the heating elements, and push together evenly to the full length of engagement without distortion of the joints. Clamp the joints and hold until fully cooled. The weld flow bead should then appear evenly around the full circumference of the socket end.



Table 8.2.2 The parameters of socket fusion

dn, mm	Socket depth, mm	Fusion temperature, °C	Heating time, s	Fusion time, s	Cooling time, s
20	14	240	5	4	2
25	15	240	7	4	2
32	16	240	8	6	4
40	18	260	12	6	4
50	20	260	18	6	4
63	24	260	24	8	6
75	26	260	30	8	8
90	29	260	40	8	8
110	32.5	260	50	10	8

Note: Socket fusion is not recommended for pipes SDR17 and below.

Mechanical Connections

As in the heat fusion methods, many types of mechanical connection styles and methods are available, such as: flange connection, PE-steel transition part...



Electrofusion

In conventional heat fusion joining, a heating tool is used to heat the pipe and fitting surfaces. The electrofusion joint is heated internally, either by a conductor at the interface of the joint or, as in one design, by a conductive polymer. Heat is created as an electric current is applied to the conductive material in the fitting. Figure 8.2.3.A illustrates a typical electrofusion joint. PE pipe to pipe connections made using the electrofusion process require the use of electrofusion couplings. The main difference between conventional heat fusion and electrofusion is the method by which the heat is applied.



Figure 8.2.3.A Typical Electrofusion

The procedure of Electrofusion

1. Cut the pipes square, and mark the pipes at a length equal to the socket depth.
2. Scrape the marked section of the pipe spigot to remove all oxidized PE layers to a depth of approximately 0.3mm. Use a hand scraper, or a rotating peel scraper to remove the PE layers. Do not use sand paper. Leave the electrofusion fittings in the sealed plastic bag until needed for assembly. Do not scrape the inside of the fitting, clean with an approved cleaner to remove all dust, dirt, and moisture.
3. Insert the pipe into the coupling up to the witness marks. Ensure pipes are rounded, and when using coiled PE pipes, rerounding clamps may be needed to remove ovality. Clamp the joint assembly.
4. Connect the electrical circuit, and follow the instructions for the particular power control box. Do not change the standard fusion conditions for the particular size and type of fitting.
5. Leave the joint in the clamp assembly until the full cooling time has been completed.



Saddle Fusion

The conventional technique to join a saddle to the side of a pipe, illustrated in Figure 8.2.4, consists of simultaneously heating both the external surface of the pipe and the matching surface of the "saddle" type fitting with concave and convex shaped heating tools until both surfaces reach proper fusion temperature. This may be accomplished by using a saddle fusion machine that has been designed for this purpose.

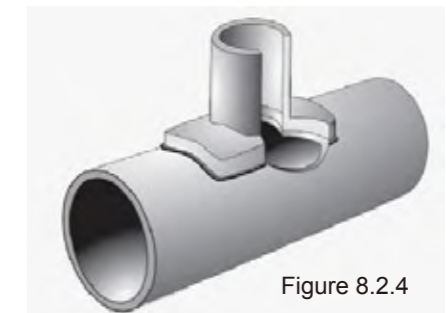

Figure 8.2.4

There are eight basic sequential steps that are normally used to create a saddle fusion joint:

1. Clean the pipe surface area where the saddle fitting is to be located
2. Install the appropriate size heater saddle adapters
3. Install the saddle fusion machine on the pipe
4. Prepare the surfaces of the pipe and fitting in accordance with the recommended procedures
5. Align the parts
6. Heat both the pipe and the saddle fitting
7. Press and hold the parts together
8. Cool the joint and remove the fusion machine

Section 9

Installation and Maintenance

The Trench

National and regional regulations and directives for soil covered pipelines are to be followed during the construction of the necessary trench. The trench has to allow all parts of the pipeline to be in frost-safe depths and enough widths.

Trench widths

Considering the project and extra effect to the pipelines from the earth, the trench width should be as narrow as possible.

Table 9.1.1.A lists recommended trench widths. These values are consistent with the principles that trench width should be as narrow as possible in order to minimize external loads and installation costs, whilst also affording sufficient space to provide the specified compaction.

The adopted actual trench width will be influenced by the soil conditions, the jointing systems, and whether joints are made in the trench.

Table 9.1.1.A Recommended trench widths

d _n of PE pipes (mm)	Trench width (mm)
20~63	150
75~110	250
12~315	500
355~500	700
560~710	910
800~1000	1200

Where PE pipes are installed with other services in common trench situations, the trench width may be specified by local authority regulations in order to permit later maintenance activities.

Trench depths

Where the PE pipe grade line is not specified, the cover over the top of the PE pipes needs to be set so that adequate protection from external loads, third party damage, and construction traffic is provided.

Where possible, pipes should be installed under minimum depth conditions and, as a guide, the values listed in Table 9.1.1.B below should be adopted.

9.1.1.B Minimum cover depths

Installation Condition		Cover over pipe crown (mm)
	Open country	300
	No pavement	450
Traffic	Sealed pavement	600
Loading	Unsealed pavement	750
	Construction equipment	750
	Embankment	750

Bedding Material & Backfill

The excavated trench floors must be trimmed even, and be free from all rocks, and hard objects. The bedding materials used in both trenches and embankments shall be one of the following:

1. Sand or soil, free from rocks greater than 15 mm, and any hard clay lumps greater than 75 mm in size.
2. Crushed rock, gravel, or graded materials of even grading with a maximum size of 15 mm.
3. Excavated material free from rocks or vegetable matter.
4. Clay lumps which can be reduced to less than 75 mm in size.

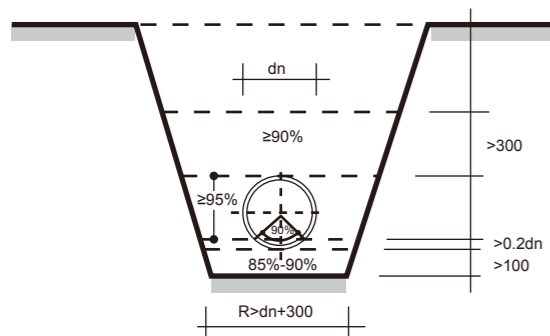

In the majority of PE pipe applications, a minimum of 75 mm of bedding material is used in both trenches and embankments in soil excavations. For excavations in rock, 150 mm bedding depth may be required.

The remainder of the trench, or embankment fill may be made with the previously excavated native materials. These must be free from large rocks, vegetable matter, and contaminated materials, and all materials must have a maximum particle size less than 75 mm.

Where PE pipelines are installed in areas with high external loads, then the backfill materials must be of the same standard as the bedding and overlay materials.

Thrust Blocks & Pipe Restraint

Thrust blocks are required for VASEN PE pipes in pressure applications where the joints do not resist longitudinal loads. The thrust blocks must be provided at all changes in direction.(Figure 9.2)

Where concrete blocks are used, the contact points between the PE pipe, or fitting and the thrust block must be protected to prevent abrasion of the PE. Rubber or malthoid sheeting may be used for this purpose.

All fittings and heavy items such as cast iron valves must be supported in order to prevent point loading on the PE materials. In addition, where valves are used, the torque loads arising from the opening/closing operations must be resisted with block supports.

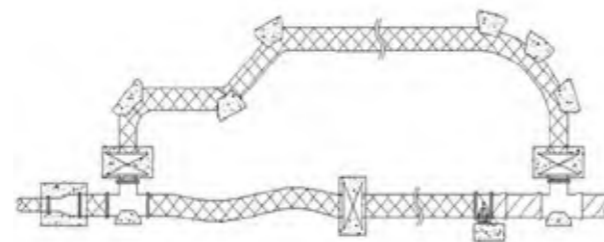

Figure 9.2

Curving of PE Pipelines

All PE pipes installed on a curved alignment must be drawn evenly over the entire curve length, and not over a short section. This can lead to kinking in small diameter, and/or thin wall pipes.

Large diameter PE pipes (450mm and above) must be joined together, and then drawn evenly to the desired radius. The Minimum allowable bend radius of HDPE pipeline can be found in Table 5.2.

Above Ground Installation

VASEN PE pipes may be installed aboveground for pressure and non pressure applications in both direct exposure and protected conditions. Black PE pipes may be used in direct sunlight exposure conditions without any additional protection. Where PE pipes of colors other than black are used in exposed conditions, then the pipes need to be protected from sunlight. Where PE pipes are installed in direct exposure conditions, then the increased PE material temperature due to exposure must be taken into account in establishing the operational pressure rating of the PE pipes. Localized temperature build up conditions such as proximity to steam lines, radiators, or exhaust



stacks must be avoided unless the PE pipes are suitably protected. Where lagging materials are used, these must be suitable for external exposure applications.

Relining & Non-dig Trench

Existing pipelines can be renovated by inserting VASEN PE pipes into the old pipes. Insertion pipes can be pulled into position by mechanical winches. Relining with PE pipes provides a structural element that is capable of withstanding either internal pressure or external loading without relying on the residual strength of the original degraded pipe elements.

The PE pipes require short length inlet and exit trenches to accommodate the PE pipe radius to lead into the existing pipeline, and the winch assembly used to pull the PE liner along the pipeline. The minimum bending radius of the PE liner can be calculated as described under Pipeline Curvature in Table 4.3 of the manual.

PE pipes can also be used in non-dig trench projects, such as Horizontal Directional Drilling (HDD). Some of the earliest uses of large diameter PE pipe in directional drilling were for river crossings. PE pipe is suited for these installations because of its scratch tolerance and the fused joining system which gives a zero-leak-rate joint with design tensile capacity equal to that of the pipe.

To date, directional drillers have installed PE pipe for gas, water, and sewer mains; communication conduits; electrical conduits; and a variety of chemical lines.

These projects involved not only river crossings but also highway crossings and right-of-ways through developed areas so as not to disturb streets, driveways, and business entrances.



Table 4.3

Repairing and Maintenance

According to different damages, there are kinds of repairing technologies to choose. Repair can be accomplished on small diameter pipe by opening sufficient trench space and cutting out the defect. Replace the damaged section with a new segment of pipe.

Repairing large diameter pipe can be accomplished with a flanged spool piece. The damaged section is removed. Next, the butt fusion machine is lowered into the ditch. Flanged connections are fused to each open end, and the flanged spool assembly is bolted into place. The flanged spool must be precisely made to fit the resulting gap in the pipeline.

EF coupler repairing (single or twin)



Cleaning & peeling

EF coupler repairing

Done

Saddle repairing (socket or EF)



Flange repairing



Quick mechanical repair

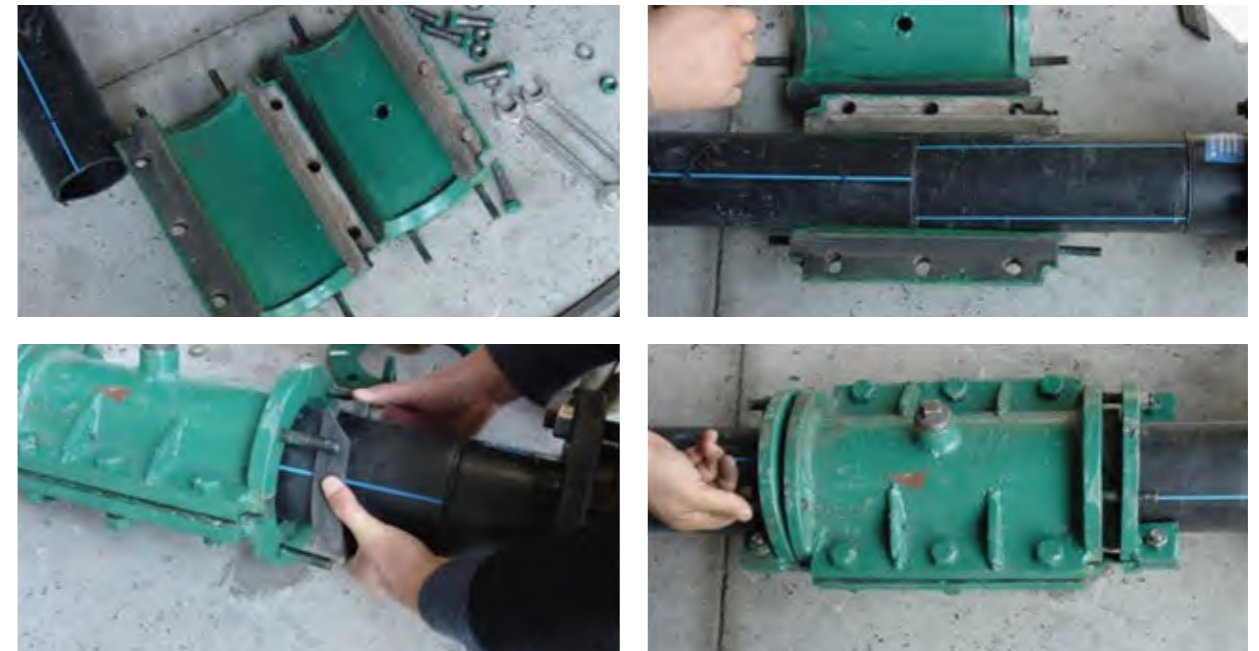

Section 10

General Precautions

Transport

Vehicles for transporting pipes should be selected in such a way so that the pipes can lay completely flat on the bed of the vehicle without any over-hang. All pipes are to be supported so that they cannot bend or become deformed. The area of the truck where the pipes are laid should be covered with either protective sheeting or cardboard (including all side supports) in order to prevent any possible damage from protruding rivets or nails etc. Pipes and fittings should be protected from possible damage during transport and not be dragged over the bed of the truck or across open ground prior to installation. Throwing pipes onto the ground from the bed of the transport truck must be prevented at all times.

Sudden shock impacts are to be avoided under all circumstances. This is especially important at ambient temperatures around or below 0° C under which circumstances the impact resistance of almost all materials is considerably reduced.

Pipes and fittings should be transported and stored in such a way so that they do not become contaminated by earth, mud, sand, stones, water, oils, chemicals, solvents, other liquids, animal excrement and the effects of weather etc. We strongly recommend that all open pipe ends are covered by protective caps to prevent the ingress of foreign substances and matter inside the pipes.

Coiled pipes are to be fastened in such a way so that they cannot become loose and damaged during their transport.

Following delivery, loose or individual pipes should be laid out flat so that they rest on their entire length as soon as possible and then secured (as soon as possible) so that they can not roll against one another. All storage surfaces in contact with the pipes must be kept free from sharp-edged objects. Storing pipes on their pallets will offer basic protection from damage.

Storage

All storage areas should be flat and kept free from stones and sharp-edged objects.

Pipes are to be stored in such a way to prevent any contamination of the insides. End closure caps should be removed just before installation.

Storage zones and stack heights are to be chosen which avoid possible damage or permanent deformation.

Large diameter pipes with low wall-thicknesses are to be provided with stiffener rings. Single point or longitudinal contact support for any pipe is to be avoided. Non-palletted pipes should be stacked in heights not exceeding 1 meter. This is not applicable for pipes which are stacked on pallets providing their full weight is supported by the frame of the pallet. In principle, coiled pipes are to be either laid flat or placed in a suitable protective framework for storage.

The location where pipe and piping components is stored must provide as much protection as possible. Pipes should not be allowed to come into contact with fuels, solvents, oil, greases, paints (silicones) or heat sources during storage.

Dragging pipes and coils over the ground must be avoided at all times.

Influence of Weather

The influence of weather on all stored piping components, is to be kept to an absolute minimum, i.e. such items should be kept in a covered warehouse. If pipes are stored in the open (for example, on construction sites) they must be covered with suitable colored or plain black sheeting to protect them from the effects of weather (e.g. UV radiation). Furthermore, a one-sided exposure to direct sunshine can ultimately lead to deformation of the pipe.

All piping components should be used in the order of their manufacture or delivery to ensure a systemized stock rotation.

Pipes and piping components should be checked before use to ensure their perfect condition and complete compliance with national marking regulations. The depth of any groove, scratch or flat abraded surface is permitted up to a total depth not exceeding 10% of the respective wall thickness. Pipes or fittings with damage in excess of this value may not be used.

Section 11

Product Range

HDPE Pipe

PE80

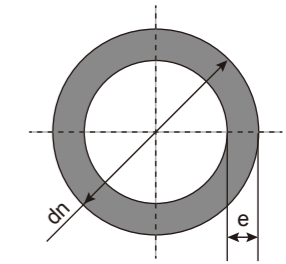
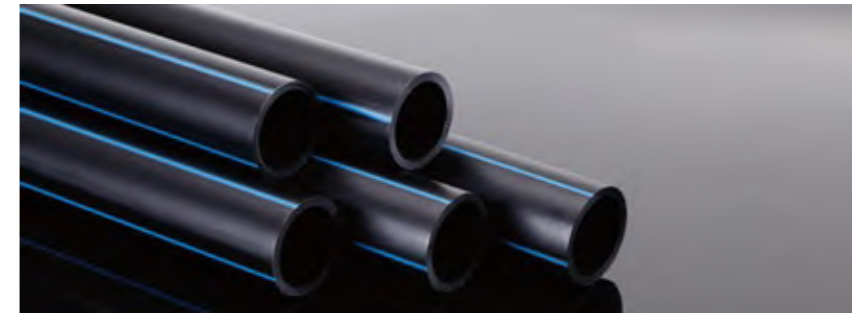

Nominal Outside Diameter(dn)	Nominal Wall Thickness & Pressure(mm & bar)				
	SDR26(PN5)	SDR21(PN6)	SDR17(PN8)	SDR13.6(PN10)	SDR11(PN12.5)
20					2.0
25				2.0	2.3
32			2.0	2.4	3.0
40			2.4	3.0	3.7
50			3.0	3.7	4.6
63		3.0	3.8	4.7	5.8
75		3.6	4.5	5.6	6.8
90	3.5	4.3	5.4	6.7	8.2
110	4.2	5.3	6.6	8.1	10
125	4.8	6	7.4	9.2	11.4
140	5.4	6.7	8.3	10.3	12.7
160	6.2	7.7	9.5	11.8	14.6
180	6.9	8.6	10.7	13.3	16.4
200	7.7	9.6	11.9	14.7	18.2
225	8.6	10.8	13.4	16.6	20.5
250	9.6	11.9	14.8	18.4	22.7
280	10.7	13.4	16.6	20.6	25.4
315	12.1	15	18.7	23.2	28.6
355	13.6	16.9	21.1	26.1	32.2
400	15.3	19.1	23.7	29.4	36.3
450	17.2	21.5	26.7	33.1	40.9
500	19.1	23.9	29.7	36.8	45.4
560	21.4	26.7	33.2	41.2	50.8
630	24.1	30	37.4	46.3	57.2
710	27.2	33.9	42.1	52.2	64.5
800	30.6	38.1	47.4	58.8	72.6
900	34.4	42.9	53.3	66.2	
1000	38.2	47.7	59.3	72.5	
1200	45.9	57.2	67.9		

PE100

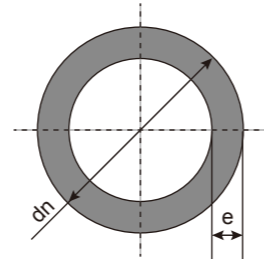
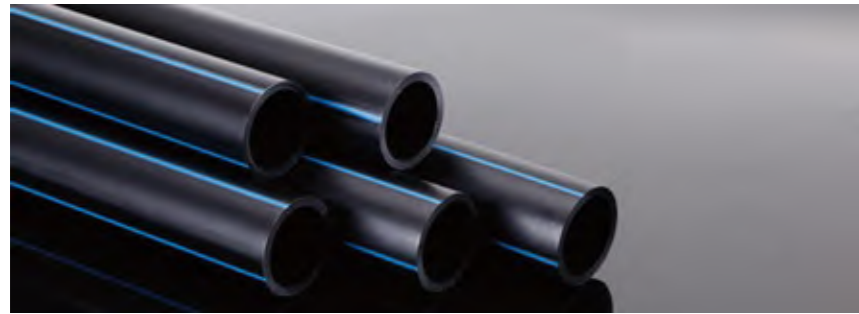

Nominal Outside Diameter(dn)	Nominal Wall Thickness & Pressure(mm & bar)				
	SDR26(PN6)	SDR21(PN8)	SDR17(PN10)	SDR13.6(PN12.5)	SDR11(PN16)
20					2.0
25				2.0	2.3
32			2.0	2.4	3.0
40			2.4	3.0	3.7
50			3.0	3.7	4.6
63		3.0	3.8	4.7	5.8
75		3.6	4.5	5.6	6.8
90	3.5	4.3	5.4	6.7	8.2
110	4.2	5.3	6.6	8.1	10
125	4.8	6	7.4	9.2	11.4
140	5.4	6.7	8.3	10.3	12.7
160	6.2	7.7	9.5	11.8	14.6
180	6.9	8.6	10.7	13.3	16.4
200	7.7	9.6	11.9	14.7	18.2
225	8.6	10.8	13.4	16.6	20.5
250	9.6	11.9	14.8	18.4	22.7
280	10.7	13.4	16.6	20.6	25.4
315	12.1	15	18.7	23.2	28.6
355	13.6	16.9	21.1	26.1	32.2
400	15.3	19.1	23.7	29.4	36.3
450	17.2	21.5	26.7	33.1	40.9
500	19.1	23.9	29.7	36.8	45.4
560	21.4	26.7	33.2	41.2	50.8
630	24.1	30	37.4	46.3	57.2
710	27.2	33.9	42.1	52.2	64.5
800	30.6	38.1	47.4	58.8	72.6
900	34.4	42.9	53.3	66.2	
1000	38.2	47.7	59.3	72.5	
1200	45.9	57.2	67.9		

Socket Fusion

Socket (WXGZ100)

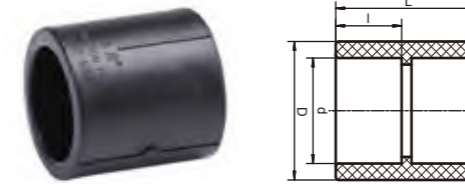

Description	d	D	L
dn20	20	27	35
dn25	25	33	39
dn32	32	42	43
dn40	40	51	47
dn50	50	63	53
dn63	63	81	61
dn75	75	95	68
dn90	90	113	75
dn110	110	138	83

Elbow 45° (WXGZ220)

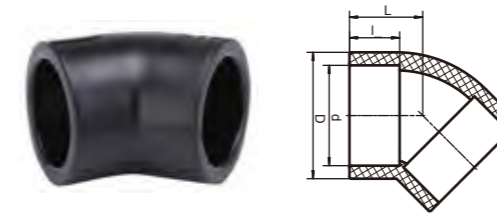

Description	d	D	L
dn20	20	27	21
dn25	25	33	24
dn32	32	42	27.5
dn40	40	51	31.5
dn50	50	63	36.5
dn63	63	81	43
dn75	75	95	50.5
dn90	90	113	56.5
dn110	110	138	65

Elbow 90° (WXGZ200)

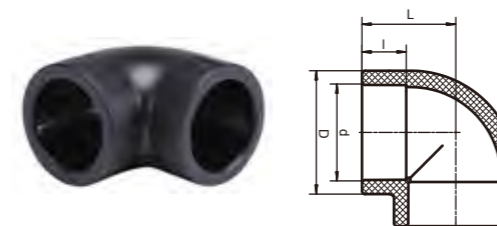

Description	d	D	L
dn20	20	27	27
dn25	25	33	31.5
dn32	32	42	37
dn40	40	51	43
dn50	50	63	51
dn63	63	81	61.5
dn75	75	95	72
dn90	90	113	83
dn110	110	138	96

Tee (WXGZ300)

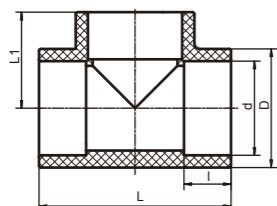

Description	d	D	L	L1
dn20	20	27	54	27
dn25	25	33	63	31.5
dn32	32	42	74	37
dn40	40	51	86	43
dn50	50	63	102	51
dn63	63	81	123	61.5
dn75	75	95	143	71.5
dn90	90	113	162	81
dn110	110	138	189	94.5

Reducer (WXGZ110)

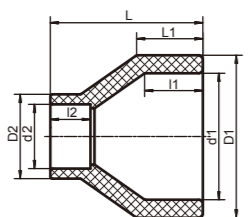

Description	d1	d2	D1	D2	L	L1
dn25×20	25	20	33	27	39	21
dn32×20	32	20	42	27	46	23
dn32×25	32	25	42	33	45	23
dn40×20	40	20	51	27	54	25.5
dn40×25	40	25	51	33	53	25.5
dn40×32	40	32	51	42	50	25.5
dn50×20	50	20	63	27	66	29
dn50×25	50	25	63	33	63	29
dn50×32	50	32	63	42	60	29
dn50×40	50	40	63	51	56	29
dn63×25	63	25	81	33	79	33
dn63×32	63	32	81	42	76	33
dn63×40	63	40	81	51	70	33
dn63×50	63	50	81	63	65	33
dn75×50	75	50	95	63	77	36
dn75×63	75	63	95	81	74	36
dn90×50	90	50	113	63	95	35
dn90×63	90	63	113	81	88	39
dn90×75	90	75	113	95	83	39
dn110×63	110	63	138	81	106	43
dn110×75	110	75	138	95	100	43
dn110×90	110	90	138	113	94	43

Reducing Tee (WXGZ310)

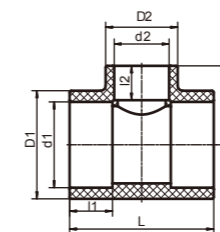

Description	d1	d2	D1	D2	L	L1
dn25×20×25	25	20	33	27	58	29.5
dn32×20×32	32	20	42	27	62	33
dn32×25×32	32	25	42	33	67	35
dn40×20×40	40	20	51	27	66	37
dn40×25×40	40	25	51	33	71	39
dn40×32×40	40	32	51	42	78	41
dn50×20×50	50	20	63	27	72	42
dn50×25×50	50	25	63	33	77	44
dn50×32×50	50	32	63	42	84	46
dn50×40×50	50	40	63	51	92	48
dn63×20×63	63	20	81	27	81	48.5
dn63×25×63	63	25	81	33	85	50.5
dn63×32×63	63	32	81	42	92	52.5
dn63×40×63	63	40	81	51	100	54.5
dn63×50×63	63	50	81	63	110	57.5
dn75×20×75	75	20	95	27	88	54.5
dn75×25×75	75	25	95	33	92.5	58
dn75×32×75	75	32	95	42	99	59.5
dn75×40×75	75	40	95	51	107	61.5
dn75×50×75	75	50	95	63	117	64.5
dn75×63×75	75	63	95	81	131	67
dn90×25×90	90	25	113	33	98	64
dn90×32×90	90	32	113	42	105	66
dn90×40×90	90	40	113	51	113	67.5
dn90×50×90	90	50	113	63	136	71
dn90×63×90	90	63	113	81	136	75
dn90×75×90	90	75	113	95	148	78
dn110×25×110	110	25	138	33	107	79
dn110×32×110	110	32	138	42	121	81
dn110×40×110	110	40	138	51	121	79
dn110×50×110	110	50	138	63	130	81
dn110×63×110	110	63	138	81	142	87
dn110×75×110	110	75	138	95	156	88
dn110×90×110	110	90	138	113	170	92

End Cap (WXGZ700)

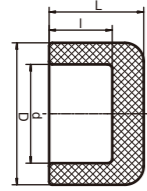

Description	d	D	L	l
dn20	20	27	20	16
dn25	25	33	23	18
dn32	32	42	26	20
dn40	40	51	28	22
dn50	50	63	32	25
dn63	63	81	39	29
dn75	75	95	43	32
dn90	90	113	48	35
dn110	110	138	54	39

Flange Adaptor (WXGZ140)

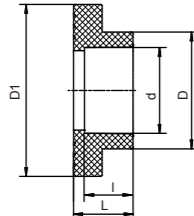

Description	d	D	D1	L	l
dn20	20	27	33	18	16
dn25	25	33	39	21	18
dn32	32	42	48	23	20
dn40	40	51	78	27	22
dn50	50	63	88	30	25
dn63	63	81	102	34	29
dn75	75	95	122	38	32
dn90	90	113	138	44	35
dn110	110	138	158	50	39

Stop Valve (WXGZ830)

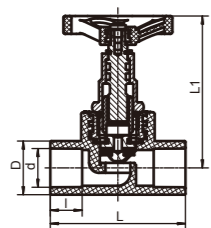

Description	d	D	L	L1
dn20	20	27	68	75
dn25	25	33	80	86
dn32	32	42	98	95
dn40	40	51	116	110
dn50	50	63	140	138
dn63	63	81	160	158

Male Thread Connector (WXGZ101)

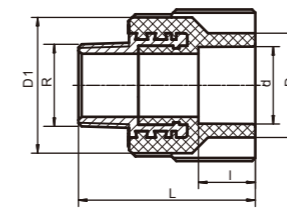

Description	d	D	D1	L	R
dn20×1/2"	20	27	35	51.5	1/2"
dn20×3/4"	20	27	43	54.5	3/4"
dn25×1/2"	25	33	35	54.5	1/2"
dn25×3/4"	25	33	43	56	3/4"
dn32×1/2"	32	42	35	56.5	1/2"
dn32×3/4"	32	42	43	60	3/4"
dn32×1"	32	42	55	75	1"
dn40×1 1/4"	40	51	66	85	1 1/4"
dn50×1 1/2"	50	63	75	93	1 1/2"
dn63×2"	63	81	92	108.5	2"
dn75×2 1/2"	75	95	107	118	2 1/2"

Female Thread Connector (WXGZ102)

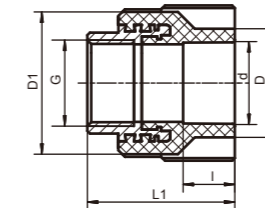

Description	d	D	D1	L	G
dn20×1/2"	20	27	37	41	1/2"
dn20×3/4"	20	27	43	43	3/4"
dn25×1/2"	25	33	37	43	1/2"
dn25×3/4"	25	33	43	43	3/4"
dn32×1/2"	32	42	37	45	1/2"
dn32×3/4"	32	42	43	45	3/4"
dn32×1"	32	42	55	57	1"
dn40×1 1/4"	40	51	68	6	1 1/4"
dn50×1 1/2"	50	63	78	70	1 1/2"
dn63×2"	63	81	95	83	2"
dn75×2 1/2"	75	100	121	94	2 1/2"

Male Thread Tee (WXGZ301)

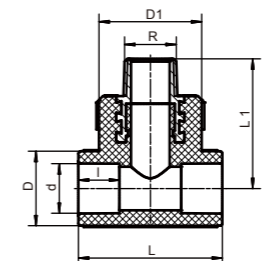

Description	d	D	D1	L	L1	R
dn20×1/2"×20	20	27	35	53	46.5	1/2"
dn20×3/4"×20	20	27	43	56	50	3/4"
dn25×1/2"×25	25	33	35	57	49.5	1/2"
dn25×3/4"×25	25	33	43	64	53	3/4"
dn32×1/2"×32	32	42	35	62	53.6	1/2"
dn32×3/4"×32	32	42	43	67	56	3/4"
dn32×1"×32	32	42	55	73	73	1"

Female Thread Tee (WXGZ302)

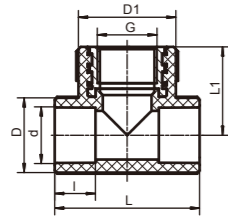

Description	d	D	D1	L	L1	G
dn20×1/2"×20	20	27	35	54	34	1/2"
dn20×3/4"×20	20	27	43	56	36	3/4"
dn25×1/2"×25	25	33	35	58	37	1/2"
dn25×3/4"×25	25	33	43	64	39	3/4"
dn32×1/2"×32	32	42	37	62	41	1/2"
dn32×3/4"×32	32	42	43	71	42	3/4"
dn32×1"×32	32	42	55	74	57	1"
dn40×1 1/4"×40	40	51	55	80	60	1 1/4"

Male Thread Elbow (WXGZ201)

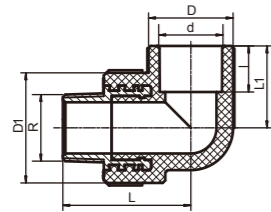

Description	d	D	D1	L	L1	R
dn20×1/2"	20	27	35	46.5	27	1/2"
dn20×3/4"	20	27	43	48	27	3/4"
dn25×1/2"	25	33	35	47.5	31	1/2"
dn25×3/4"	25	33	43	50	32	3/4"
dn32×3/4"	32	42	43	54.5	30	3/4"
dn32×1"	32	42	55	54	40	1"
dn63×2"	63	82	96	110	67	2"

Female Thread Elbow (WXGZ202)

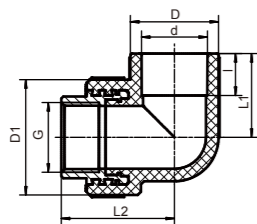

Description	d	D	D1	L	L1	G
dn20×1/2"	20	27	35	34	27	1/2"
dn20×3/4"	20	27	43	34	27.5	3/4"
dn25×1/2"	25	33	35	36	32	1/2"
dn25×3/4"	25	33	43	36	32	3/4"
dn32×1/2"	32	42	37	40	35	1/2"
dn32×3/4"	32	42	43	40	37	3/4"
dn32×1"	32	42	35	54	/	1"
dn63×2"	63	81	95	/	83	2"

Saddle (WXGZ150)

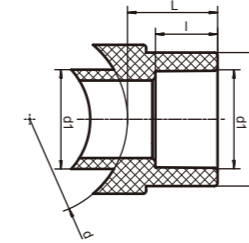

Description	d	d1	D	L
dn50×25	50	25	33	27
dn63×25	63	25	33	27
dn63×32	63	32	42	29
dn75×25	75	25	33	27
dn75×32	75	32	42	29
dn90×25	90	25	33	27
dn90×32	90	32	42	29
dn110×25	110	25	33	27
dn110×32	110	32	42	29
dn125×25	125	25	33	27
dn125×32	125	32	42	29
dn140×25	140	25	33	27
dn140×32	140	32	42	29
dn160×25	160	25	33	27
dn160×32	160	32	42	29
dn180×25	180	25	33	27
dn180×32	180	32	42	29
dn200×25	200	25	33	27
dn200×32	200	32	42	29

Reducing Elbow 90° (WXGZ210)

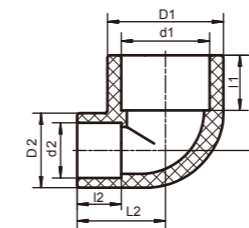

Description	d1	d2	D1	D2	L1	L2
dn25×20	25	20	33	27	31.5	29.5
dn32×20	32	20	42	27	34.5	32
dn32×25	32	25	42	33	37	35

Cross (WXGZ400)

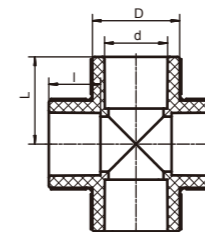

Description	d	D	L
dn20	20	27	27
dn25	25	33	31.5
dn32	32	42	37

Female Thread Union (Metal/Plastic) (WXGZ104)

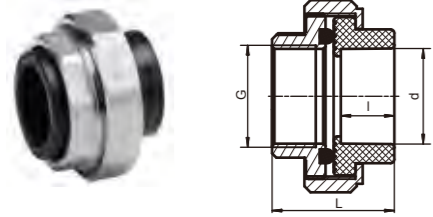

Description	d	L	G
dn20×1/2"	20	38	1/2"
dn20×3/4"	20	37	3/4"
dn25×1/2"	25	39	1/2"
dn25×3/4"	25	39	3/4"
dn32×1"	32	47	1"
dn40×1 1/4"	40	49	1 1/4"
dn50×1 1/2"	50	55	1 1/4"
dn63×2"	63	61	2"
dn75×2 1/2"	75	70	2 1/2"

Male Thread Union (Metal/Plastic) (WXGZ103)

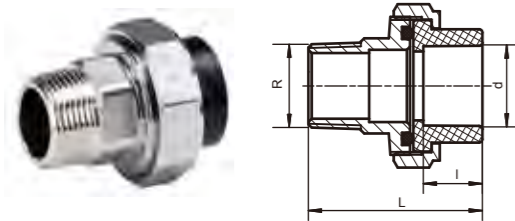

Description	d	L	R
dn20×1/2"	20	55	1/2"
dn20×3/4"	20	54.5	3/4"
dn25×1/2"	25	56	1/2"
dn25×3/4"	25	61	3/4"
dn25×1"	25	60	1"
dn32×3/4"	32	61	3/4"
dn32×1"	32	69	1"
dn40×1 1/4"	40	76	1 1/4"
dn50×1 1/2"	50	80	1 1/4"
dn63×2"	63	88	2"
dn75×2 1/2"	75	93	2 1/2"

Female Thread Saddle (WXGZ152)

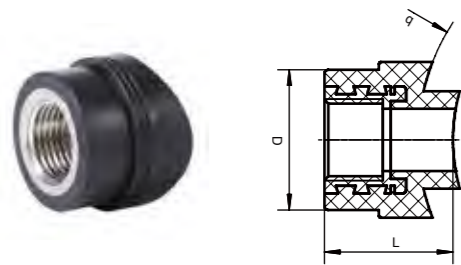

Description	d	D	L
dn63x25x1/2"	63	36	33
dn75x32x1"	75	61	44
dn90x32x1"	90	61	44
dn110x25x1/2"	110	36	33
dn110x32x1"	110	61	44
dn160x32x1"	160	61	44

Union (WXGZ109)

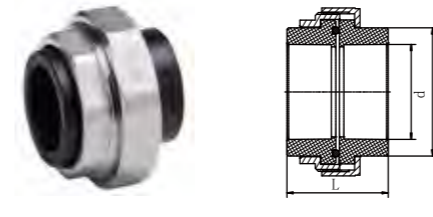

Description	d	D	L	L1
dn20	20	28	37	16
dn25	25	34.5	43	18
dn32	32	44	48	20
dn40	40	53	53	22
dn50	50	67	60	25
dn63	63	84	66	29

Double Union Ball Valve (WXGZ800)

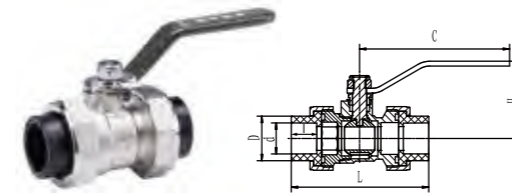

Description	d	D	L	l	H	C
dn20	15	20	87	16	55	90
dn25	21	25	98	18	58	105
dn32	27	32	105	20	68	125
dn40	36	40	122	22	80	132
dn50	45	50	133	25	83	145
dn63	59	63	156	29	95	165

Single Union & Male Thread Ball Valve (WXGZ810)

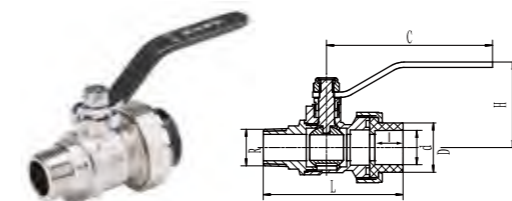

Description	d	D	L	l	H	R	C
dn20x1/2"	20	28	80	16	55	1/2"	90
dn25x3/4"	25	34	88	18	58	3/4"	105
dn32x1"	32	43	102	20	68	1"	125

Single Union & Female Thread Ball Valve (WXGZ820)

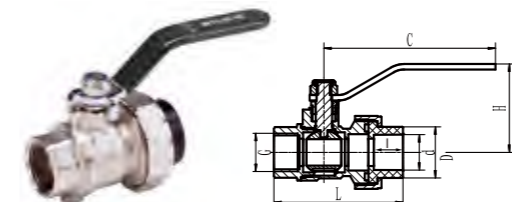

Description	d	D	L	l	H	G	C
dn20x1/2"	20	15	71	16	55	1/2"	90
dn25x3/4"	25	21	79	18	58	3/4"	105
dn32x1"	32	27	90	20	68	1"	125

Butt Fusion

Reducer (WXGZ1100)

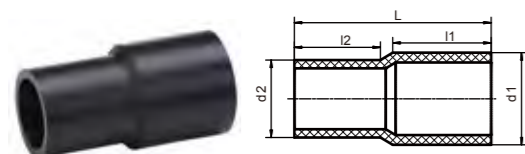

Description	d1	d2	L
dn50×40	50	40	110
dn63×32	63	32	130
dn63×40	63	40	132
dn63×50	63	50	150
dn75×50	75	50	148
dn75×63	75	63	143
dn90×50	90	50	158
dn90×63	90	63	165
dn90×75	90	75	160
dn110×50	110	50	178
dn110×63	110	63	182
dn110×75	110	75	182
dn110×90	110	90	177
dn125×63	125	63	182
dn125×75	125	75	182
dn125×90	125	90	180
dn125×110	125	110	182
dn140×110	140	110	192
dn140×125	140	125	197
dn160×50	160	50	215
dn160×63	160	63	217
dn160×90	160	90	222
dn160×110	160	110	229
dn160×125	160	125	211
dn160×140	160	140	200
dn180×63	180	63	226
dn180×90	180	90	228
dn180×125	180	125	230
dn180×160	180	160	232
dn200×63	200	63	255
dn200×75	200	75	265
dn200×90	200	90	255
dn200×110	200	110	244
dn200×125	200	125	236

Reducer (WXGZ1100)

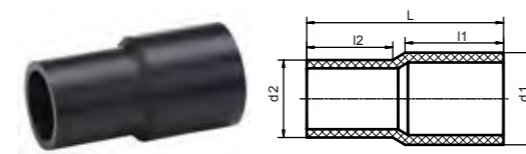

Description	d1	d2	L
dn200×160	200	160	231
dn200×180	200	180	265
dn225×110	225	110	285
dn225×125	225	125	285
dn225×140	225	140	255
dn225×160	225	160	258
dn225×200	225	200	248
dn250×90	250	90	300
dn250×110	250	110	294
dn250×125	250	125	299
dn250×160	250	160	289
dn250×180	250	180	289
dn250×200	250	200	274
dn250×225	250	225	266
dn280×160	280	160	303
dn280×200	280	200	276
dn280×250	280	250	289
dn315×110	315	110	350
dn315×160	315	160	340
dn315×180	315	180	316
dn315×200	315	200	336
dn315×225	315	225	340
dn315×250	315	250	345
dn315×280	315	280	307
dn355×250	355	250	323
dn355×315	355	315	365
dn400×140	400	140	415
dn400×160	400	160	310
dn400×200	400	200	310
dn400×250	400	250	385
dn400×315	400	315	395
dn400×355	400	355	310
dn450×400	450	400	410
dn500×450	500	450	410
dn560×500	560	500	410
dn630×450	630	450	410
dn630×560	630	560	410

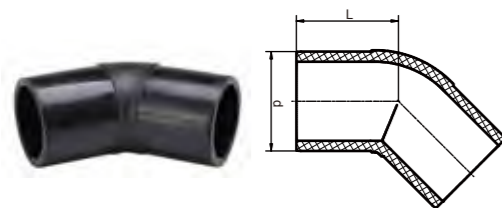
Elbow 45° (WXGZ2200)

Description	d	L
dn50	50	80
dn63	63	85
dn75	75	96
dn90	90	106
dn110	110	113
dn125	125	121
dn140	140	130
dn160	160	132
dn180	180	150
dn200	200	165
dn225	225	180
dn250	250	193
dn280	280	212
dn315	315	230
dn355	355	248
dn400	400	263
dn450	450	302
dn500	500	321
dn560	560	332
dn630	630	344

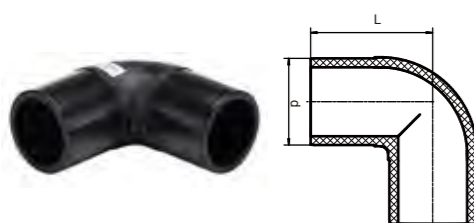
Elbow 90° (WXGZ2000)

Description	d	L
dn40	40	77
dn50	50	89
dn63	63	105
dn75	75	130
dn90	90	140
dn110	110	155
dn125	125	165
dn140	140	176
dn160	160	185
dn180	180	210
dn200	200	230
dn225	225	252
dn250	250	276
dn280	280	308
dn315	315	330
dn355	355	360
dn400	400	390
dn450	450	420
dn500	500	450
dn560	560	477
dn630	630	506

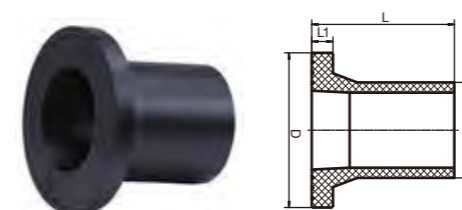
Stub End (Flange Adaptor) (WXGZ1400)

Description	d	D	L	L1
dn40	40	78	83	13
dn50	50	88	85	12
dn63	63	102	94	14
dn75	75	122	105	16.5
dn90	90	138	117	17
dn110	110	158	128	18
dn125	125	158	133	22
dn140	140	188	127	20
dn160	160	212	176	22
dn180	180	212	180	28
dn200	200	268	182	32
dn225	225	269	180	32
dn250	250	320	205	35
dn280	280	320	210	35
dn315	315	374	210	35
dn355	355	435	225	40
dn400	400	485	240	45
dn450	450	530	260	47
dn500	500	588	280	47
dn560	560	670	280	51
dn630	630	690	280	51
dn710	710	800	300	60
dn800	800	905	305	60
dn900	900	1005	340	74
dn1000	1000	1110	350	74
dn1200	1200	1330	370	80

End Cap (WXGZ7000)

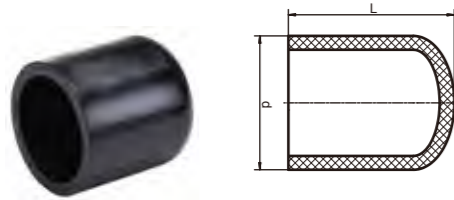

Description	d	L
dn32	32	55
dn50	50	70
dn63	63	82
dn75	75	93
dn90	90	106
dn110	110	123
dn125	125	124
dn140	140	128
dn160	160	132
dn180	180	183
dn200	200	190
dn225	225	179
dn250	250	192
dn280	280	200
dn315	315	216
dn355	355	230
dn400	400	255
dn450	450	220
dn500	500	220
dn560	560	220
dn630	630	220

Tee (WXGZ3000)

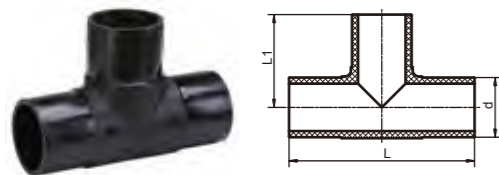

Description	d	L	L1
dn63	63	210	105
dn75	75	230	115
dn90	90	280	140
dn110	110	310	155
dn125	125	340	170
dn140	140	352	176
dn160	160	380	190
dn180	180	420	210
dn200	200	460	230
dn225	225	495	262
dn250	250	550	275
dn280	280	594	297
dn315	315	670	335
dn355	355	720	382
dn400	400	770	422
dn500	500	857	496
dn630	630	990	580

Reducing Tee (WXGZ3100)

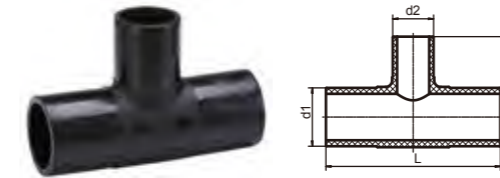

Description	d1	d2	L	L1
dn75×32×75	75	32	200	92
dn75×63×75	75	63	225	110
dn90×32×90	90	32	218	100
dn90×40×90	90	40	213	118
dn90×50×90	90	50	230	111
dn90×63×90	90	63	269	124
dn90×75×90	90	75	255	125
dn110×32×110	110	32	223	124
dn110×40×110	110	40	231	129
dn110×50×110	110	50	235	120
dn110×63×110	110	63	310	137
dn110×75×110	110	75	258	135
dn110×90×110	110	90	310	153
dn125×63×125	125	63	340	150
dn125×75×125	125	75	276	158
dn125×90×125	125	90	340	166
dn125×110×125	125	110	312	170
dn140×63×140	140	63	335	145
dn140×75×140	140	75	335	155
dn140×90×140	140	90	335	165
dn140×110×140	140	110	335	170
dn160×32×160	160	32	272	167
dn160×40×160	160	40	268	165
dn160×50×160	160	50	287	162
dn160×63×160	160	63	295	157
dn160×75×160	160	75	315	178
dn160×90×160	160	90	370	193
dn160×110×160	160	110	340	177
dn160×125×160	160	125	363	195
dn180×63×180	180	63	300	168
dn180×90×180	180	90	330	184
dn180×110×180	180	110	370	213
dn180×125×180	180	125	365	192
dn180×160×180	180	160	402	217
dn200×50×200	200	50	314	180
dn200×63×200	200	63	323	179
dn200×75×200	200	75	357	190
dn200×90×200	200	90	350	195
dn200×110×200	200	110	370	199

Reducing Tee (WXGZ3100)

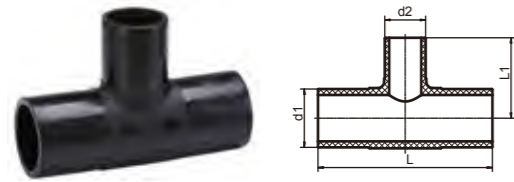

Description	d1	d2	L	L1
dn200×125×200	200	125	370	215
dn200×160×200	200	160	420	215
dn200×180×200	200	180	442	223
dn225×75×225	225	75	375	207
dn225×90×225	225	90	413	248
dn225×110×225	225	110	400	220
dn225×140×225	225	140	440	235
dn225×160×225	225	160	460	235
dn225×200×225	225	200	465	252
dn250×63×250	250	63	365	208
dn250×90×250	250	90	393	224
dn250×110×250	250	110	405	223
dn250×125×250	250	125	425	230
dn250×160×250	250	160	460	241
dn250×180×250	250	180	480	250
dn250×200×250	250	200	500	255
dn250×225×250	250	225	505	276
dn280×90×280	280	90	568	255
dn280×110×280	280	110	423	236
dn280×160×280	280	160	474	254
dn280×225×280	280	225	539	276
dn315×90×315	315	90	445	262
dn315×110×315	315	110	470	265
dn315×125×315	315	125	470	265
dn315×160×315	315	160	480	272
dn315×180×315	315	180	530	285
dn315×200×315	315	200	560	300
dn315×225×315	315	225	555	305
dn315×250×315	315	250	605	313
dn355×250×355	355	250	596	337
dn355×315×355	355	315	673	364
dn400×140×400	400	140	548	329
dn400×355×400	400	355	719	404
dn500×400×500	500	400	770	456
dn500×450×500	500	450	814	481

Injection Steel Flange Plate (WXG9010)

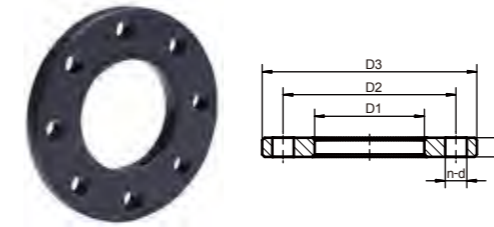

Description	n	d	E	D1	D2	D3
dn63	4	22	20	77	125	160
dn75	4	18	20	92	145	185
dn90	8	22	20	104	160	195
dn110	8	22	22	122	180	220
dn125	8	22	22	133	180	220
dn160	8	22	24	170	240	284
dn200	12	22	24	233	295	338
dn225	12	22	24	233	295	338
dn250	12	22	27	279	350	395
dn315	12	22	27	333	400	445
dn400	16	30	28	418	525	580

Steel Flange Plate (WXG9000)

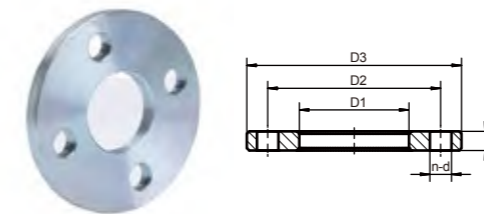

Description	n	d	E	D1	D2	D3
dn50	4	18	14	61	110	145
dn63	4	18	16	77	125	160
dn75	4	18	16	92	145	180
dn90	8	18	16	104	160	195
dn110	8	18	18	122	180	220
dn125	8	18	18	133	180	220
dn140	8	18	20	158	210	250
dn160	8	22	20	170	240	284
dn180	8	22	20	187	240	284
dn200	12	22	20	233	295	338
dn225	12	22	20	233	295	338
dn250	12	26	23	279	355	405
dn280	12	26	23	295	355	405
dn315	12	26	24	333	410	460
dn355	16	26	26	373	470	520
dn400	16	30	28	418	525	580
dn450	20	30	30	475	585	640
dn500	20	33	32	535	650	715
dn560	20	36	33	620	770	840
dn630	20	36	33	647	770	840

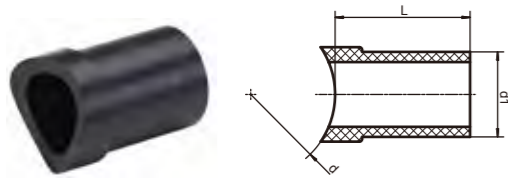
Saddle (WXGZ1500)

Description	d	d1	L
dn110×50	110	50	85
dn140×63	140	63	100
dn160×75	160	75	110
dn225×90	225	90	117
dn250×110	250	110	115
dn280×125	280	125	170
dn315×160	315	160	173
dn355×180	355	180	185
dn400×200	400	200	185
dn450×225	450	225	195
dn500×250	500	250	205
dn560×250	560	250	205
dn630×315	630	315	220

Elbow 22.5° (WXGH2210)

Description	D	H1	H2
dn50	50	56	75
dn63	63	56	75

Elbow 11.25° (WXGH2110)

Description	D	H1	H2
dn50	50	56	75
dn63	63	63	85

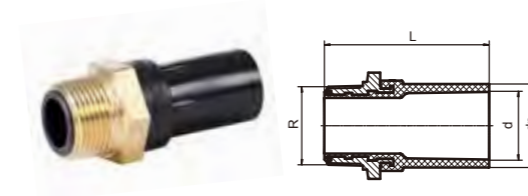
Male Transition (WXGZ1010)

Description	dn	d	L	R
dn32×1"	32	25.5	92	1"
dn40×1-1/4"	40	32	100	1 1/4"
dn50×1-1/2"	50	40	108.5	1 1/2"
dn63×2"	63	49	124	2"

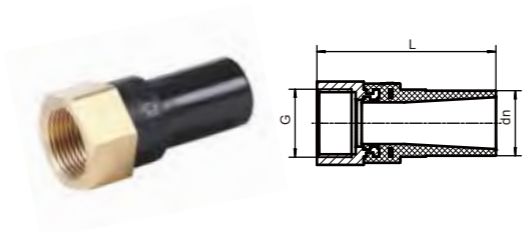
Female Transition (WXGZ1020)

Description	dn	G	L
dn32×1"	32	1"	88
dn40×1-1/4"	40	1 1/4"	97
dn50×1-1/2"	50	1 1/2"	110
dn63×2"	63	2"	129

Electrofusion

Elbow 45° (WXGD220)



Description	d	D	L
dn32	32	47	54
dn40	40	56	62
dn50	50	68	70
dn63	63	81	80
dn75	75	94	88
dn90	90	116	95
dn110	110	141	115
dn125	125	159	118
dn160	160	203	138
dn180	180	230	147
dn200	200	254	165
dn250	250	316	191
dn280	280	343	192
dn315	315	384	235
dn355 (SDR17)	355	405	263
dn400 (SDR17)	400	452	300
dn450 (SDR17)	450	510	321
dn500 (SDR17)	500	564	333
dn560 (SDR17)	560	632	344

Elbow 90° (WXGD200)



Description	d	D	L
dn25	25	40	55
dn32	32	47	62
dn40	40	56	71
dn50	50	68	82
dn63	63	81	100
dn75	75	94	111
dn90	90	116	122
dn110	110	141	145
dn125	125	159	156
dn140	140	177	168
dn160	160	203	182
dn180	180	230	198
dn200	200	257	215
dn250	250	316	261
dn280	280	343	271
dn315	315	384	315
dn355 (SDR17)	355	405	389
dn400 (SDR17)	400	452	418
dn450 (SDR17)	450	510	450
dn500 (SDR17)	500	564	477
dn560 (SDR17)	560	632	506

Coupler (WXGD100)



Description	d	D	L
dn20	20	32	73
dn25	25	36	70
dn32	32	47	77
dn40	40	56	85
dn50	50	68	94
dn63	63	81	113
dn75	75	96	125
dn90	90	114	145
dn110	110	133	155
dn125	125	151	160
dn140	140	177	165
dn160	160	196	170
dn180	180	215	180
dn200	200	242	210
dn225	225	279	210
dn250	250	304	244
dn280	280	348	260
dn315	315	380	285
dn355 SDR11 (39.5V)	355	430	315
dn400 SDR11 (42V)	400	484	335
dn450 SDR11 (80V)	450	546	360
dn500 SDR11 (80V)	500	599	370
dn560 SDR11 (80V)	560	685	430
dn630 SDR11 (80V)	630	750	430

Repairing Saddle (WXGD3220)

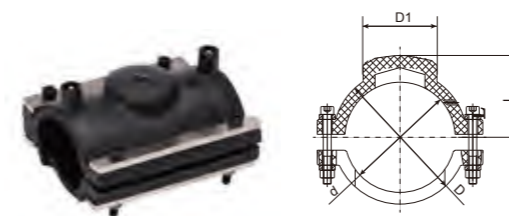

Description	d	D	D1	L
dn63	63	78	50	44
dn90	90	114	70	62
dn110	110	134	74	72
dn160	160	194	83	102
dn200	201.2	240	90	125

Reducer (WXGD110)

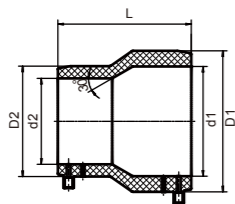

Description	d1	d2	D1	D2	L
dn32×25	32	25	47	40	90
dn40×32	40	32	56	47	95
dn50×32	50	32	68	47	108
dn50×40	50	40	68	56	107
dn63×32	63	32	81	47	126
dn63×40	63	40	81	56	125
dn63×50	63	50	81	68	122
dn75×40	75	40	96	56	140
dn75×63	75	63	96	81	135
dn90×50	90	50	116	68	155
dn90×63	90	63	116	81	148
dn90×75	90	75	116	96	146
dn110×63	110	63	141	81	178
dn110×75	110	75	141	96	176
dn110×90	110	90	141	116	175
dn125×63	125	63	159	81	187
dn125×90	125	90	159	116	184
dn125×110	125	110	159	141	163
dn160×90	160	90	203	116	220
dn160×110	160	110	203	141	220
dn160×125	160	125	203	159	192
dn180×90	180	90	230	116	245
dn180×125	180	125	230	159	215
dn200×90	200	90	254	117	265
dn200×110	200	110	257	141	264
dn200×160	200	160	257	203	235
dn250×160	250	160	314	204	273
dn250×180	250	180	314	230	255
dn250×200	250	200	314	254	245
dn315×160	315	160	396	206	360
dn315×200	315	200	396	254	350
dn315×250	315	250	396	318	340

Flange Adaptor (WXGD140)

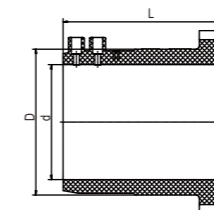

Description	d	D	L
dn50	50	65	110
dn63	63	80	123
dn75	75	96	133
dn90	90	145	112
dn110	110	137	155
dn160	160	194	170
dn200	200	240	182
dn250	250	300	185
dn315	354	414	185

Tee (WXGD300)

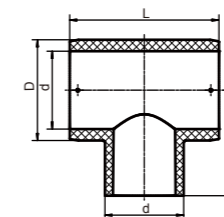

Description	d	D	L	L1
dn25	25	40	100	64
dn32	32	47	110	70
dn40	40	56	127	80
dn50	50	68	156	100
dn63	63	81	178	122
dn75	75	96	191	131
dn90	90	116	226	144
dn110	110	141	255	160
dn125	125	159	270	175
dn160	160	203	317	211
dn180	180	230	341	241
dn200	200	254	400	255
dn250	250	318.5	450	310
dn315	315	396	590	390
dn355 (SDR17)	355	402	719	403
dn400 (SDR17)	400	452	760	428
dn450 (SDR17)	450	510	814	481
dn500 (SDR17)	500	564	858	524
dn560 (SDR17)	560	632	929	565

Reducing Tee (WXGD310)

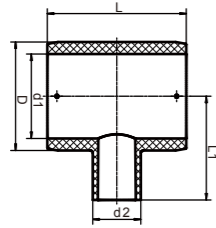

Description	d1	d2	D	L	L1
dn32×25×32	32	25	47	110	68
dn40×25×40	40	25	56	120	72
dn40×32×40	40	32	56	130	75
dn50×25×50	50	25	68	146	78
dn50×32×50	50	32	68	146	81
dn50×40×50	50	40	68	146	81
dn63×25×63	63	25	81	156	86
dn63×32×63	63	32	81	156	90
dn63×40×63	63	40	81	156	94
dn63×50×63	63	50	81	156	98
dn75×63×75	75	63	96	178	115
dn90×40×90	90	40	116	200	115
dn90×50×90	90	50	116	200	125
dn90×63×90	90	63	116	200	125
dn110×32×110	110	32	141	220	120
dn110×40×110	110	40	141	220	125
dn110×50×110	110	50	141	220	125
dn110×63×110	110	63	141	220	150
dn110×90×110	110	90	141	245	160
dn125×63×125	125	63	159	220	150
dn125×90×125	125	90	159	245	165
dn125×110×125	125	110	159	257	171
dn160×50×160	160	50	203	241	170
dn160×63×160	160	63	203	238	182
dn160×90×160	160	90	203	277	198
dn160×110×160	160	110	203	277	198
dn160×125×160	160	125	203	300	206
dn180×125×180	180	125	230	310	215
dn200×63×200	200	63	256	270	205
dn200×90×200	200	90	254	285	215
dn200×110×200	200	110	254	310	220
dn200×160×200	200	160	254	360	240
dn250×125×250	250	125	312	350	255
dn250×160×250	250	160	312	380	270
dn250×180×250	250	180	312	400	290
dn250×200×250	250	200	305	392	287
dn315×200×315	315	200	396	525	340
dn315×250×315	315	250	385	533	365

Branch Saddle (WXGD3200)

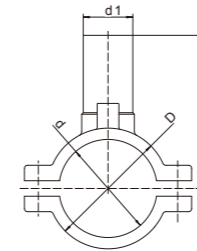

Description	d	d1	D	L
dn63×32	63	32	78	99
dn90×32	90	32	114	117
dn90×63	90	63	110	202
dn110×32	110	32	134	121
dn110×63	110	63	134	147
dn125×63	125	63	154	157
dn160×63	160	63	194	177
dn160×90	160	90	183	181
dn200×63	200	63	240	200
dn250×63	250	63	300	230

Tapping Saddle (WXGD3210)

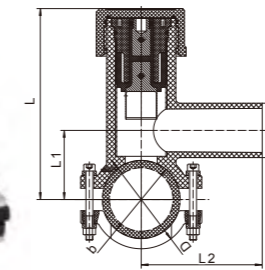

Description	d	d1	D	L	L1	L2
dn63×32	63	32	78	139	55	70
dn90×63	90	63	114	221	80	140
dn110×63	110	63	134	231	90	140
dn160×32	160	32	194	199	118	110
dn160×63	160	63	194	271	130	140
dn160×90	160	90	183	385	170	206
dn200×63	200	63	240	294	153	140
dn250×90	250	90	273	445	230	206
dn315×90	315	90	341	465	250	206
dn315×110	315	110	341	490	215	206

Transition Fitting

Steel/PE Transition Fitting (dn ≤ 63)

PE80/PE100/PE100-RC SDR11

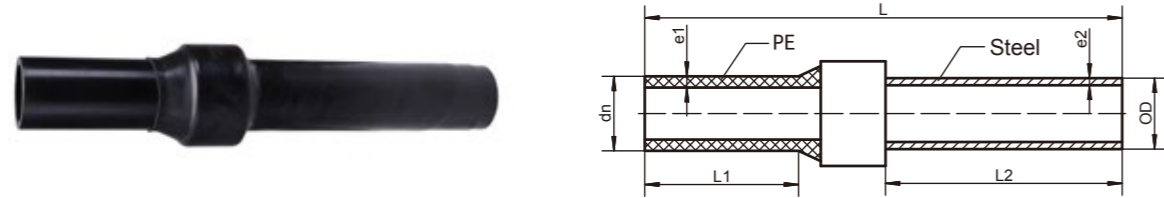

Description	L	L1	L2	e1	e2
dn32/OD32×250	410	95	250	3.0	4.0
dn32/OD34×250	410	95	250	3.0	4.0
dn40/OD34×250	420	105	250	3.7	4.0
dn40/OD42×250	420	105	250	3.7	4.0
dn40/OD48×250	420	105	250	3.7	4.0
dn50/OD42×250	435	120	250	4.6	4.0
dn50/OD48×250	435	120	250	4.6	4.0
dn63/OD48×250	460	140	250	5.8	4.0
dn63/OD57×250	460	140	250	5.8	4.0
dn63/OD60×250	460	140	250	5.8	4.0

The steel pipe is 20# seamless steel pipe, the surface corrosion protection can be divided into FBE anti-corrosion and 3PE anti-corrosion; Length L2 of steel pipe can be customized according to customer requirements (≤1.8m).

Steel/PE Transition Fitting (dn > 63)

PE80/PE100/PE100-RC SDR11/17

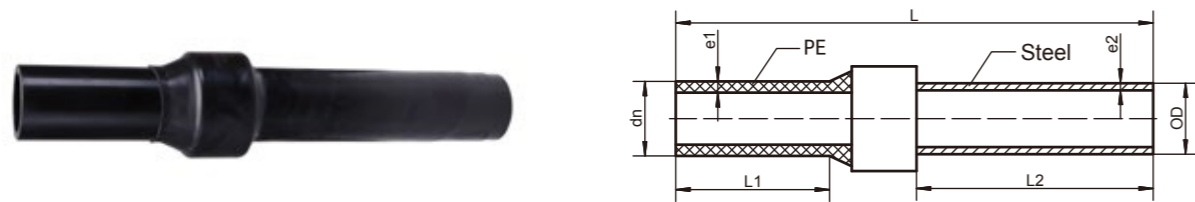

Description	L	L1	L2	e1		e2
				SDR11	SDR17	
dn90/OD89×250	525	170	250	8.2	5.4	6.0
dn110/OD108×250	525	175	250	10.0	6.6	6.0
dn160/OD159×250	565	180	250	14.6	9.5	6.0
dn200/OD219×350	680	180	350	18.2	11.9	6.0
dn250/OD219×350	586	129	395	22.7	14.8	6.0

The steel pipe is 20# seamless steel pipe, the surface corrosion protection can be divided into FBE anti-corrosion and 3PE anti-corrosion; Length L2 of steel pipe can be customized according to customer requirements (≤0.6m).

Threaded Steel/PE Transition Fitting

PE80/PE100/PE100-RC SDR11

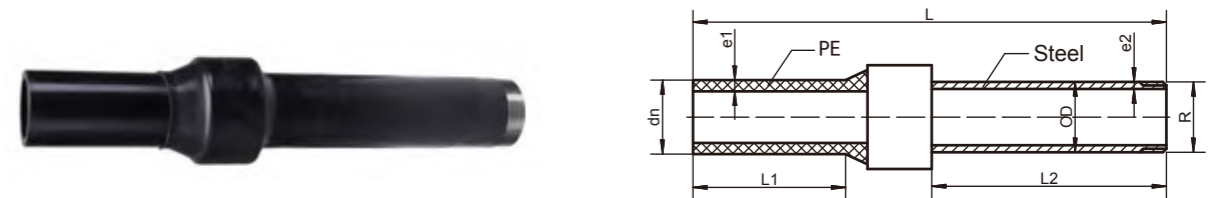

Description	L	L1	L2	e1	e2	OD
dn32/R1×250	410	95	250	3.0	4.0	34
dn40/ R1×250	420	105	250	3.7	4.0	34
dn40/ R1-1/4×250	420	105	250	3.7	4.0	42
dn40/R1-1/2×250	420	105	250	3.7	4.0	48
dn50/ R1-1/4×250	435	120	250	4.6	4.0	42
dn50/ R1-1/2×250	435	120	250	4.6	4.0	48
dn63/ R1-1/2×250	460	140	250	5.8	4.0	48
dn63/ R2×250	460	140	250	5.8	4.0	60

The steel pipe is 20# seamless steel pipe, the surface corrosion protection can be divided into FBE anti-corrosion and 3PE anti-corrosion; Length L2 of steel pipe can be customized according to customer requirements (≤1.8m).

Steel/PE Transition Fitting of Large-diameter

PE80/PE100/PE100-RC SDR11/17



Description	L	L1	L2	e1		e2
				SDR11	SDR17	
dn250/OD273×350	840	350	350	22.7	14.8	8.0
dn315/OD299×350	627	178	355	28.6	18.7	8.0
dn315/OD325×350	840	350	350	28.6	18.7	8.0
dn355/OD325×350	530	164	350	32.2	21.1	8.0
dn400/OD426×350	735	179	400	36.4	23.7	8.0

The steel pipe is 20# seamless steel pipe, the surface corrosion protection can be divided into FBE anti-corrosion and 3PE anti-corrosion; Length L2 of steel pipe can be customized according to customer requirements (≤0.6m).

Steel/PE Transition Elbow 90° (FBE Anti-corrosion)

PE80/PE100/PE100-RC SDR11



Description	L1	L2*	L3*	e1	e2
dn32/OD32×300/800	95	300	800	3.0	4.0
dn32/OD34×300/800	95	300	800	3.0	4.0
dn40/OD34×300/800	105	300	800	3.7	4.0
dn40/OD42×300/800	105	300	800	3.7	4.0
dn40/OD48×300/800	105	300	800	3.7	4.0
dn50/OD42×300/800	120	300	800	4.6	4.0
dn50/OD48×300/800	120	300	800	4.6	4.0
dn63/OD48×300/800	140	300	800	5.8	4.0
dn63/OD57×330/800	140	330	800	5.8	4.0
dn63/OD60×350/800	140	350	800	5.8	4.0

The steel pipe is 20# seamless steel pipe, the surface corrosion protection is FBE anti-corrosion ;
The length of steel pipes L2 and L3 can be customized according to customer requirements (L2≤0.5m, L3≤1.6m).

Steel/PE Transition Elbow 90° (3PE Anti-corrosion)

PE80/PE100/PE100-RC SDR11



Description	L1	L2	L3	e1	e2
dn32/OD32×300/800	95	300	800	3.0	4.0
dn32/OD34×300/800	95	300	800	3.0	4.0
dn40/OD34×300/800	105	300	800	3.7	4.0
dn40/OD42×330/800	105	330	800	3.7	4.0
dn40/OD48×350/800	105	350	800	3.7	4.0
dn50/OD42×330/800	120	330	800	4.6	4.0
dn50/OD48×350/800	120	350	800	4.6	4.0
dn63/OD48×350/800	140	350	800	5.8	4.0
dn63/OD57×430/800	140	430	800	5.8	4.0
dn63/OD60×450/800	140	450	800	5.8	4.0

The steel pipe is 20# seamless steel pipe, the surface corrosion protection is 3PE anti-corrosion ;
The length of steel pipes L2 and L3 can be customized according to customer requirements (L2≤0.5m, L3≤1.6m).

Threaded Steel/PE Transition Elbow 90° (FBE Anti-corrosion)

PE80/PE100/PE100-RC SDR11



Description	L1	L2	L3	e1	e2	OD
dn32/R1×300/800	95	300	800	3.0	4.0	34
dn40/ R1×300/800	105	300	800	3.7	4.0	34
dn40/ R1-1/4×300/800	105	300	800	3.7	4.0	42
dn40/ R1-1/2×300/800	105	300	800	3.7	4.0	48
dn50/ R1-1/4×300/800	120	300	800	4.6	4.0	42
dn50/ R1-1/2×300/800	120	300	800	4.6	4.0	48
dn63/ R1-1/2×300/800	140	300	800	5.8	4.0	48
dn63/ R2×350/800	140	350	800	5.8	4.0	60

The steel pipe is 20# seamless steel pipe, the surface corrosion protection is FBE anti-corrosion ;
The length of steel pipes L2 and L3 can be customized according to customer requirements (L2≤0.5m, L3≤1.6m).

Threaded Steel/PE Transition Elbow 90° (3PE Anti-corrosion)

PE80/PE100/PE100-RC SDR11



Description	L1	L2	L3	e1	e2	OD
dn32/R1×300/800	95	300	800	3.0	4.0	34
dn40/ R1×300/800	105	300	800	3.7	4.0	34
dn40/ R1-1/4×330/800	105	330	800	3.7	4.0	42
dn40/ R1-1/2×350/800	105	350	800	3.7	4.0	48
dn50/ R1-1/4×330/800	120	330	800	4.6	4.0	42
dn50/ R1-1/2×350/800	120	350	800	4.6	4.0	48
dn63/ R1-1/2×350/800	140	350	800	5.8	4.0	48
dn63/ R2×450/800	140	450	800	5.8	4.0	60

The steel pipe is 20# seamless steel pipe, the surface corrosion protection is 3PE anti-corrosion ;
The length of steel pipes L2 and L3 can be customized according to customer requirements (L2≤0.5m, L3≤1.6m).

Butt Fusion Welding Machine

CHHJ-160SA



PLASTIC BUTTFUSION WELDING MACHINE CHHJ-160MM(A)

MAIN TECHNICAL DATA:

POWER: 2200W

MILLING POWER: 700W

HEATER POWER: 1500W

PATED VOLTAGE: A.C 220/230V, 50/60HZ

WORKING TEMPERATURE OF HEATER: 180 C -280 C

ENVIRONMENT TEMPERATURE: -5 C -45 C

MAX. WELDING DIAMETER: 160MM

MIN. WELDING DIAMETER: 50MM

THE MACHINERY SUITABLE FOR: PE,PP,PB,PVDF

INCLUDING THE FOLLOWING ACCESSORIES:

1 SET OF MACHINE AND RACK;

1 PC HEATER PLATE;

1 PC MILLING INSTRUMENT;

1 PC STORAGE BOX;

1 SET OF ALUMINUM CLAMPS: 50.63.75.90.110.125.140

CHHJ-160SB



PLASTIC BUTTFUSION WELDING MACHINE CHHJ-160MM(B)

MAIN TECHNICAL DATA:

POWER: 2200W

MILLING POWER: 700W

HEATER POWER: 1500W

PATED VOLTAGE: A.C 220/230V, 50/60HZ

WORKING TEMPERATURE OF HEATER: 180 C -280 C

ENVIRONMENT TEMPERATURE: -5 C -45 C

MAX. WELDING DIAMETER: 160/250MM

MIN. WELDING DIAMETER: 50MM

THE MACHINERY SUITABLE FOR: PE,PP,PB,PVDF

INCLUDING THE FOLLOWING ACCESSORIES:

1 SET OF MACHINE AND RACK;

1 PC HEATER PLATE;

1 PC MILLING INSTRUMENT;

1 PC STORAGE BOX;

1 SET OF ALUMINUM CLAMPS: 50.63.75.90.110.125.140

CHDHJ-160



PLASTIC BUTTFUSION WELDING MACHINE CHDHJ-160MM

MAIN TECHNICAL DATA:

MAX. OIL PRESSURE:10 MPa

POWER: 2950W

HEATER POWER: 1500W

MILLING POWER: 700W

PUMP POWER: 750W

PATED VOLTAGE: A.C 220/230V, 50/60HZ

WORKING TEMPERATURE OF HEATER: 180 C -280 C

ENVIRONMENT TEMPERATURE: -5 C -45 C

MAX. WELDING DIAMETER: 160MM

MIN. WELDING DIAMETER: 50MM

THE MACHINERY SUITABLE FOR: PE,PP,PB,PVDF

INCLUDING THE FOLLOWING ACCESSORIES:

1 SET OF MACHINE AND RACK;

1 PC HEATER PLATE;

1 PC MILLING INSTRUMENT;

1 PC STORAGE BOX;

1 PC PUMP;

1 SET OF ALUMINUM CLAMPS: 50.63.75.90.110.125.140.

CHHJ-200SA



PLASTIC BUTTFUSION WELDING MACHINE CHHJ-200MM(A)

MAIN TECHNICAL DATA:

POWER: 2200W

MILLING POWER: 700W

HEATER POWER: 1500W

PATED VOLTAGE: A.C 220/230V, 50/60HZ

WORKING TEMPERATURE OF HEATER: 180 C -280 C

ENVIRONMENT TEMPERATURE: -5 C -45 C

MAX. WELDING DIAMETER: 200MM

MIN. WELDING DIAMETER: 90MM

THE MACHINERY SUITABLE FOR: PE,PP,PB,PVDF

INCLUDING THE FOLLOWING ACCESSORIES:

1 SET OF MACHINE AND RACK;

1 PC HEATER PLATE;

1 PC MILLING INSTRUMENT;

1 PC STORAGE BOX;

1 SET OF ALUMINUM CLAMPS: 90.110.125.140.160.180

CHDHJ-250



PLASTIC BUTTFUSION WELDING MACHINE CHDHJ-250MM

MAIN TECHNICAL DATA:

MAX. OIL PRESSURE:10 MPa

POWER: 4600W

MILLING POWER: 1100W

HEATER POWER: 2000W

PUMP POWER: 1500W

PATED VOLTAGE: A.C 220/230V, 50/60HZ

WORKING TEMPERATURE OF HEATER: 180 C-280 C

ENVIRONMENT TEMPERATURE: -5 C-45 C

MAX. WELDING DIAMETER: 250MM

MIN. WELDING DIAMETER: 90MM

THE MACHINERY SUITABLE FOR: PE,PP,PB,PVDF

INCLUDING THE FOLLOWING ACCESSORIES:

1 SET OF MACHINE AND RACK;

1 PC HEATER PLATE;

1 PC MILLING INSTRUMENT;

1 PC STORAGE BOX;

1 PC PUMP;

1 SET OF ALUMINUM CLAMPS:90.110.125.140.160.180.200.250

CHHJ-250SA



PLASTIC BUTTFUSION WELDING MACHINE CHHJ-250MM(A)

MAIN TECHNICAL DATA:

POWER: 2200W

MILLING POWER: 700W

HEATER POWER: 1500W

PATED VOLTAGE: A.C 220/230V, 50/60HZ

WORKING TEMPERATURE OF HEATER: 180 C-280 C

ENVIRONMENT TEMPERATURE: -5 C-45 C

MAX. WELDING DIAMETER: 250MM

MIN. WELDING DIAMETER: 90MM

THE MACHINERY SUITABLE FOR: PE,PP,PB,PVDF

INCLUDING THE FOLLOWING ACCESSORIES:

1 SET OF MACHINE AND RACK;

1 PC HEATER PLATE;

1 PC MILLING INSTRUMENT;

1 PC STORAGE BOX;

1 SET OF ALUMINUM CLAMPS: 90.110.125.140.160.180.200.225

CHDHJ-315



PLASTIC BUTTFUSION WELDING MACHINE CHDHJ-315MM

MAIN TECHNICAL DATA:

MAX. OIL PRESSURE:10 MPa

POWER: 5100W

HEATER POWER: 2500W

MILLING POWER:1100W

PUMP POWER: 1500W

PATED VOLTAGE: A.C 220/230V, 50/60HZ

WORKING TEMPERATURE OF HEATER: 180 C-280 C

ENVIRONMENT TEMPERATURE: -5 C-45 C

MAX. WELDING DIAMETER: 315MM

MIN. WELDING DIAMETER: 160MM

THE MACHINERY SUITABLE FOR: PE,PP,PB,PVDF

INCLUDING THE FOLLOWING ACCESSORIES:

1 SET OF MACHINE AND RACK;

1 PC HEATER PLATE;

1 PC MILLING INSTRUMENT;

1 PC STORAGE BOX;

1 PC PUMP;

1 SET OF ALUMINUM CLAMPS: 160.180.200.225.250.280

CHDHJ-400



PLASTIC BUTTFUSION WELDING MACHINE CHDHJ-400MM

MAIN TECHNICAL DATA:

MAX. OIL PRESSURE:10 MPa

POWER: 6.3KW

HEATER POWER: 3.0KW

MILLING POWER:1.1KW

PUMP POWER: 2.2KW

PATED VOLTAGE: A.C 220/230V, 50/60HZ

WORKING TEMPERATURE OF HEATER: 180 C-280 C

ENVIRONMENT TEMPERATURE: -5 C-45 C

MAX. WELDING DIAMETER: 400MM

MIN. WELDING DIAMETER:160MM

THE MACHINERY SUITABLE FOR: PE,PP,PB,PVDF

INCLUDING THE FOLLOWING ACCESSORIES:

1 SET OF MACHINE AND RACK;

1 PC HEATER PLATE;

1 PC MILLING INSTRUMENT;

1 PC STORAGE BOX;

1 PC PUMP;

1 SET OF ALUMINUM CLAMPS: 160.180.200.225.250.280.315.355

CHDHJ-450



PLASTIC BUTTFUSION WELDING MACHINE CHDHJ-450MM

MAIN TECHNICAL DATA:

MAX. OIL PRESSURE:10 MPa

POWER: 7.2KW

HEATER POWER: 3.5KW

MILLING POWER:1.5KW

PUMP POWER: 2.2KW

PATED VOLTAGE: A.C 220/230V, 50/60HZ

WORKING TEMPERATURE OF HEATER: 180℃-280℃

ENVIRONMENT TEMPERATURE: -5℃-45℃

MAX. WELDING DIAMETER: 450MM

MIN. WELDING DIAMETER:250MM

THE MACHINERY SUITABLE FOR: PE,PP,PB,PVDF

INCLUDING THE FOLLOWING ACCESSORIES:

1 SET OF MACHINE AND RACK;

1 PC HEATER PLATE;

1 PC MILLING INSTRUMENT;

1 PC STORAGE BOX;

1 PC PUMP;

1 SET OF ALUMINUM CLAMPS: 250.280.315.355.400

CHDHJ-630



PLASTIC BUTTFUSION WELDING MACHINE CHDHJ-630MM

MAIN TECHNICAL DATA:

MAX. OIL PRESSURE:10 MPa

POWER: 10.2KW

HEATER POWER: 6.5KW

MILLING POWER:1.5KW

PUMP POWER: 2.2KW

PATED VOLTAGE: A.C 220/230V, 50/60HZ

WORKING TEMPERATURE OF HEATER: 180℃-280℃

ENVIRONMENT TEMPERATURE: -5℃-45℃

MAX. WELDING DIAMETER: 630MM

MIN. WELDING DIAMETER:315MM

THE MACHINERY SUITABLE FOR: PE,PP,PB,PVDF

INCLUDING THE FOLLOWING ACCESSORIES:

1 SET OF MACHINE AND RACK;

1 PC HEATER PLATE;

1 PC MILLING INSTRUMENT;

1 PC STORAGE BOX;

1 PC PUMP;

1 SET OF ALUMINUM CLAMPS: 315.355.400.450.500.560

CHDHJ-800



PLASTIC BUTTFUSION WELDING MACHINE CHDHJ-800MM

MAIN TECHNICAL DATA:

MAX. OIL PRESSURE:12 MPa

POWER: 16.2KW

HEATER POWER: 12.5KW

MILLING POWER: 2.2KW

PUMP POWER: 1.5KW

PATED VOLTAGE: A.C 220/230V, 50/60HZ

WORKING TEMPERATURE OF HEATER: 180℃-280℃

ENVIRONMENT TEMPERATURE: -5℃-45℃

MAX. WELDING DIAMETER: 800MM

MIN. WELDING DIAMETER:630MM

THE MACHINERY SUITABLE FOR: PE,PP,PB,PVDF

INCLUDING THE FOLLOWING ACCESSORIES:

1 SET OF MACHINE AND RACK;

1 PC HEATER PLATE;

1 PC MILLING INSTRUMENT;

1 PC STORAGE BOX;

1 PC PUMP;

1 SET OF ALUMINUM CLAMPS: 630.710

Electrofusion Welding Machine

DRJ-III



PLASTIC ELECTROFUSION WELDING MACHINE DRJ-III

MAIN TECHNICAL DATA:

INPUT POWER VOLTAGE: 175V~250V AC

OUTPUT VOLTAGE: 39.5V AC

FREQUENCY: 50HZ

OUTPUT POWER: 3.5KW

ENVIRONMENT TEMPERATURE: -15℃~50℃

RELATIVE HUMIDITY: ≤80%

TIME ADJUSTED RADIUS: 1~2999s

TIME RESOLUTION: 1s

BALANCED TIME: ≤1s

BALANCED OUTPUT VOLTAGE: ≤2.5%

PROTECTION LEVEL: IP54

WEIGHT: 20 KG

SIZE OF APPEARANCE: 400*300*250mm

Socket Fusion Welding Machine

ZRJQ-63



PLASTIC SOCKET FUSION WELDING MACHINE ZRJQ-63

MAIN TECHNICAL DATA:

POWER: 800/870W

RATED VOLTAGE: A.C 220/230V, 50/60HZ

MAX. WELDING DIAMETER: 63MM

MIN. WELDING DIAMETER: 20MM

WORKING TEMPERATURE: 200-279 °C ±1%

ENVIRONMENT TEMPERATURE: -5 °C -45 °C

APPLICABLE MATERIAL: PE, PP, PB, PVDF

NET WEIGHT OF MACHINE: 1.8 KG

PCS/CARTON: 2

CARTON SIZE: 460*265*265 MM

WEIGHT/CARTON: 16.5 KGS

INCLUDING THE FOLLOWING ACCESSORIES:

1 PC FUSION TOOL;

1 PC METAL CASE (BIG METAL CASE OPTIONAL);

1 PC UNDERPIN RACK;

1 PC TABLE-BOARD CLAMP (OPTIONAL);

1 BAG OF BOLTS AND HEX KEY WRENCH;

SOCKETS D20, D25, D32, D40, D50, D63 (OPTIONAL)

ZRJQ-110



PLASTIC SOCKET FUSION WELDING MACHINE ZRJQ-110

MAIN TECHNICAL DATA:

POWER: 1200/1310W

RATED VOLTAGE: A.C 220/230V, 50/60HZ

MAX. WELDING DIAMETER: 110MM

MIN. WELDING DIAMETER: 75MM

WORKING TEMPERATURE: 200-279 °C ±1%

ENVIRONMENT TEMPERATURE: -5 °C -45 °C

APPLICABLE MATERIAL: PE, PP, PB, PVDF

NET WEIGHT OF MACHINE: 2.0 KG

PCS/CARTON: 2

CARTON SIZE: 460*265*265 MM

WEIGHT/CARTON: 21.5 KGS

INCLUDING THE FOLLOWING ACCESSORIES:

1 PC FUSION TOOL;

1 PC METAL CASE (BIG METAL CASE OPTIONAL);

1 PC UNDERPIN RACK;

1 PC TABLE-BOARD CLAMP (OPTIONAL);

1 BAG OF BOLTS AND HEX KEY WRENCH;

SOCKETS D75, D90, D110 (OPTIONAL)